

# GSM3368ASF

## 30V N-Channel Enhancement Mode MOSFET

### Product Description

The N-Channel enhancement mode power field effect transistor is using trench DMOS technology. This advanced technology has been especially tailored to minimize on-state resistance, provide superior switching performance, and withstand high energy pulse in the avalanche and commutation mode.

The device is well suited for high efficiency fast switching applications.

### Features

- $R_{DS(ON)} = 6m\Omega @ V_{GS} = 10V$
- $R_{DS(ON)} = 9.8m\Omega @ V_{GS} = 4.5V$
- SOP-8 Package

### Applications

- MB / VGA / Vcore
- POL
- SMPS

### Packages & Pin Assignments

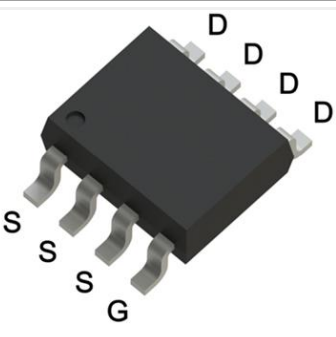
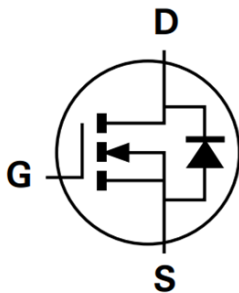
GSM3368ASF (SOP-8)		Equivalent Circuit
		
Pin	Description	
1	Source	
2	Source	
3	Source	
4	Gate	
5	Drain	
6	Drain	
7	Drain	
8	Drain	

## Ordering and Marking Information

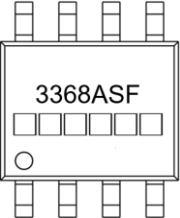
Ordering Information			
Part Number	Package	Part Marking	Quantity / Reel
GSM3368ASF	SOP-8	3368ASF □□□□□□	4,000 PCS
<b>GSM3368A</b> <span style="border: 1px solid black; padding: 0 2px;">1</span> <span style="border: 1px solid black; padding: 0 2px;">2</span>			
- <b>Product Code:</b> GSM3368A		- <b>Package Code:</b> <span style="border: 1px solid black; padding: 0 2px;">1</span> is <b>S</b> for SOP-8	
- <b>Green Level:</b> <span style="border: 1px solid black; padding: 0 2px;">2</span> is <b>F</b> for RoHS Compliant and Halogen Free			
Marking Information			
		- <b>Product Code:</b> 3368ASF	
		- <b>GS Code:</b> □□□□□□	

## Absolute Maximum Ratings

T<sub>A</sub>=25°C, unless otherwise specified

Symbol	Parameter	Value	Unit
V <sub>DSS</sub>	Drain-Source Voltage	30	V
V <sub>GSS</sub>	Gate-Source Voltage	±20	V
I <sub>D</sub>	Continuous Drain Current <sup>1</sup>	T <sub>A</sub> =25°C	13
		T <sub>A</sub> =70°C	10
I <sub>DM</sub>	Pulsed Drain Current <sup>2</sup>	65	A
P <sub>D</sub>	Total Power Dissipation <sup>3</sup>	T <sub>A</sub> =25°C	1.5
		T <sub>A</sub> =70°C	1
T <sub>J</sub>	Operating Junction Temperature Range	-55 to +150	°C
T <sub>STG</sub>	Storage Temperature Range	-55 to +150	°C
R <sub>θJA</sub>	Thermal Resistance, Junction to Ambient <sup>1</sup>	80	°C/W

Note:

1. The data tested by surface mounted on a 1 inch<sup>2</sup> FR-4 board with 2oz copper.
2. The data tested by pulsed, pulse width ≤ 300us, duty cycle ≤ 2%.
3. The power dissipation is limited by 150°C junction temperature.

## Electrical Characteristics

TA=25°C, unless otherwise specified

Symbol	Parameter	Test Conditions	Min.	Typ.	Max.	Unit
<b>Static characteristics</b>						
BV <sub>DSS</sub>	Drain-Source Breakdown Voltage	V <sub>GS</sub> =0V, I <sub>D</sub> =250μA	30	-	-	V
V <sub>GS(th)</sub>	Gate Threshold Voltage	V <sub>DS</sub> =V <sub>GS</sub> , I <sub>D</sub> =250μA	1.2	-	2.5	V
I <sub>GSS</sub>	Gate-Source Leakage Current	V <sub>DS</sub> =0V, V <sub>GS</sub> =±20V	-	-	±100	nA
I <sub>DSS</sub>	Drain-Source Leakage Current	V <sub>DS</sub> =30V, V <sub>GS</sub> =0V	-	-	1	μA
R <sub>DS(ON)</sub>	Drain-Source On-Resistance	V <sub>GS</sub> =10V, I <sub>D</sub> =15A	-	4.2	6	mΩ
		V <sub>GS</sub> =4.5V, I <sub>D</sub> =10A	-	5.6	9.8	
V <sub>SD</sub>	Diode Forward Voltage	V <sub>GS</sub> =0V, I <sub>S</sub> =20A	-	-	1.2	V
<b>Dynamic characteristics</b>						
C <sub>iss</sub>	Input Capacitance	V <sub>DS</sub> =15V, V <sub>GS</sub> =0V, f=1MHz	-	2295	2750	pF
C <sub>oss</sub>	Output Capacitance		-	267	-	
C <sub>rss</sub>	Reverse Transfer Capacitance		-	210	-	
R <sub>g</sub>	Gate Resistance	V <sub>DS</sub> =0V, V <sub>GS</sub> =0V, f=1MHz	-	1.7	-	Ω
Q <sub>g</sub>	Total Gate Charge	V <sub>DS</sub> =15V, V <sub>GS</sub> =10V, I <sub>D</sub> =10A	-	39	56	nC
Q <sub>gs</sub>	Gate-Source Charge		-	7.6	-	
Q <sub>gd</sub>	Gate-Drain Charge		-	7.2	-	
t <sub>d(on)</sub>	Turn-On Delay Time	V <sub>DS</sub> =15V, V <sub>GS</sub> =10V, R <sub>g</sub> =3.3Ω, I <sub>D</sub> =10A	-	7.8	-	ns
t <sub>r</sub>	Turn-On Rise Time		-	15	-	
t <sub>d(off)</sub>	Turn-Off Delay Time		-	37	-	
t <sub>f</sub>	Turn-Off Fall Time		-	11	-	

## Typical Performance Characteristics

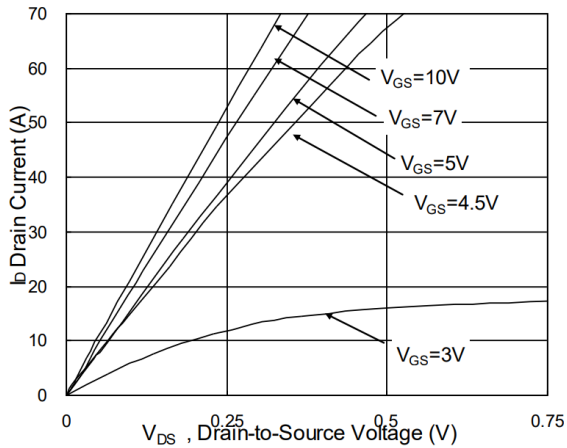

Figure 1. Typical Output Characteristics

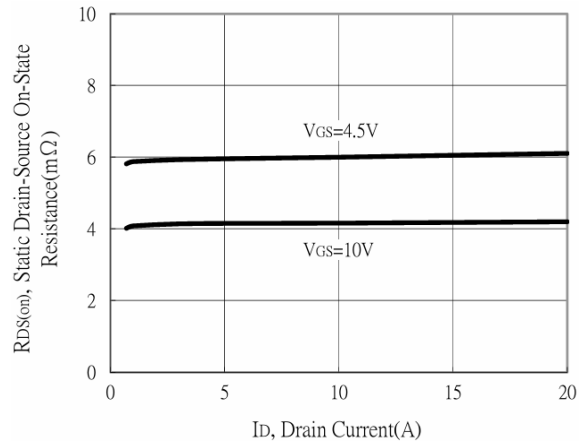

Figure 2. Drain-Source On-State resistance vs Drain Current

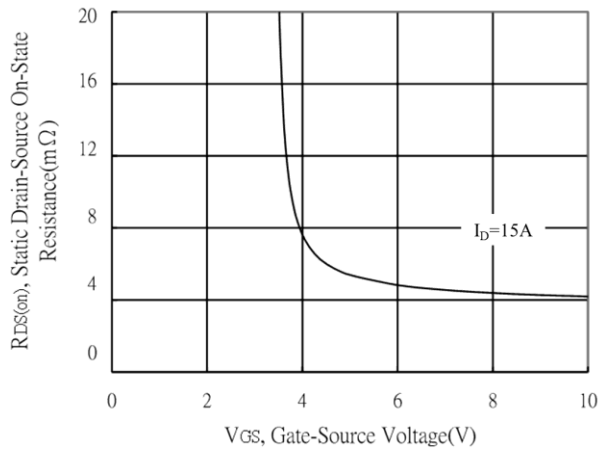

Figure 3. Drain-Source On-State Resistance vs Gate-Source Voltage

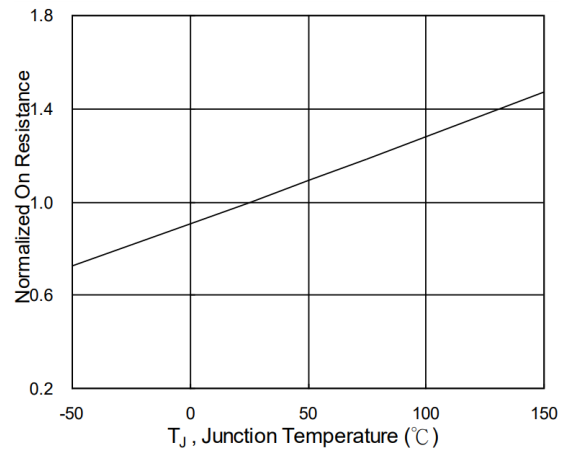

Figure 4. Drain-Source On-State Resistance vs Junction Temperature

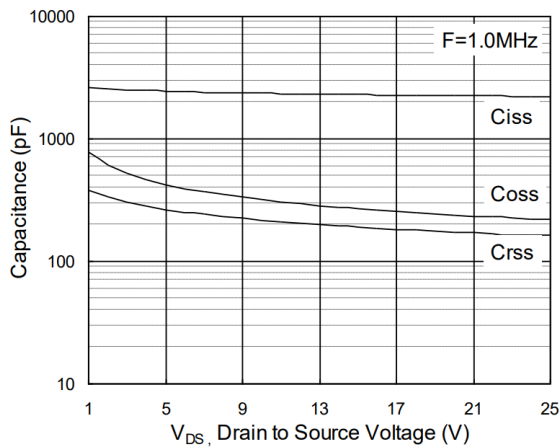

Figure 5. Capacitance vs Drain-to-Source Voltage

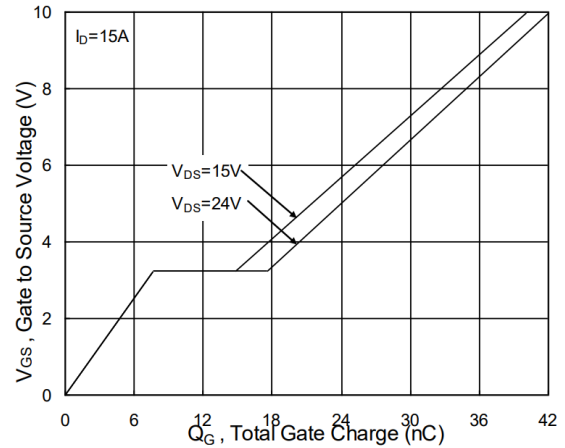

Figure 6. Gate Charge

## Typical Performance Characteristics

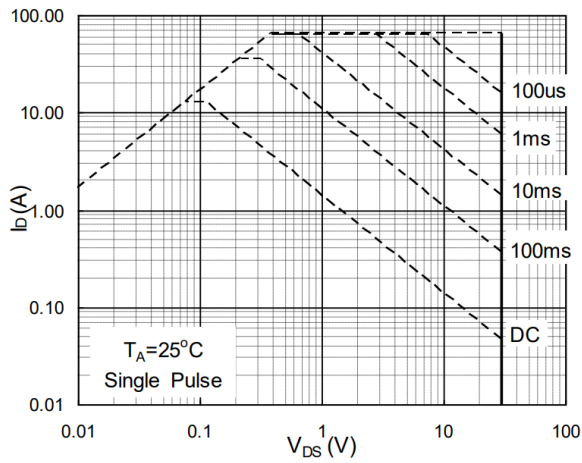

Figure 7. Maximum Safe Operating Area

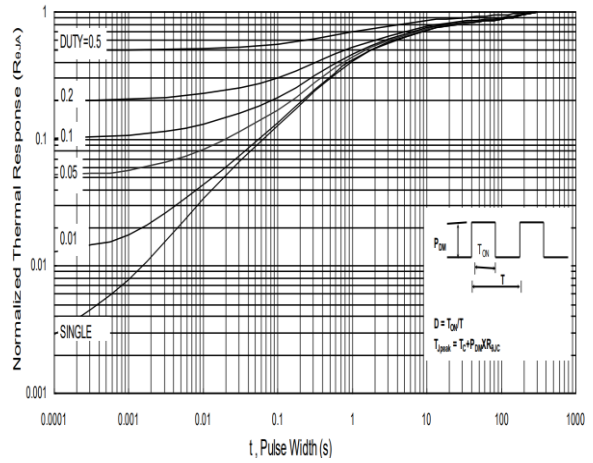
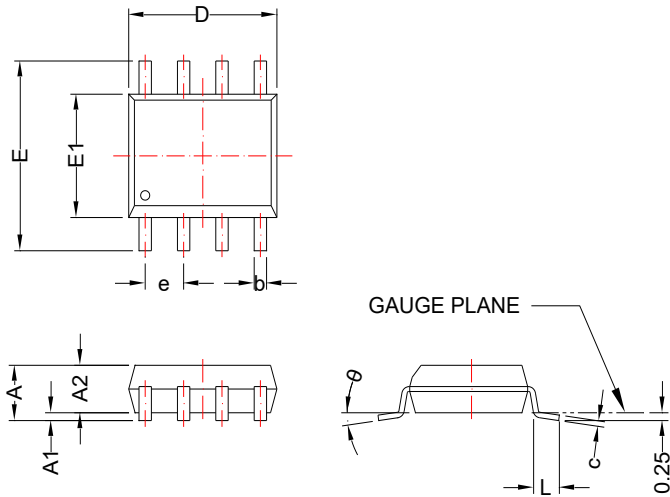

Figure 8. Normalized Transient Thermal Resistance

# SOP-8

## Package Dimension



## Recommended Land Pattern

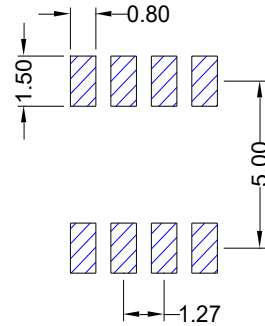





Dimensions				
Symbol	Millimeters		Inches	
	MIN	MAX	MIN	MAX
<b>A</b>	-	1.75	-	0.069
<b>A1</b>	0.10	0.25	0.004	0.010
<b>A2</b>	1.25	-	0.049	-
<b>b</b>	0.31	0.51	0.012	0.020
<b>c</b>	0.10	0.25	0.004	0.010
<b>D</b>	4.70	5.10	0.185	0.201
<b>E</b>	5.80	6.20	0.228	0.244
<b>E1</b>	3.80	4.00	0.150	0.157
<b>e</b>	1.27 BSC		0.050 BSC	
<b>L</b>	0.4	1.27	0.016	0.050
<b>θ</b>	0°	8°	0°	8°



NOTE:  
 DIMENSION D DOES NOT INCLUDE MOLD FLASH, PROTRUSIONS OR GATE BURRS. MOLD FLASH, PROTRUSIONS OR GATE BURRS SHALL NOT EXCEED 0.15 mm PER END.

## NOTICE

- Globaltech Semiconductor assumes no responsibility for equipment failures that result from using products at values that exceed, even momentarily, rated values (such as maximum ratings, operating condition ranges, or other parameters) listed in products specifications of any and all Globaltech Semiconductor products described or contained herein. Globaltech Semiconductor products are not designed for use in life support appliances, devices or systems where malfunction of these products can be reasonably expected to result in personal injury. Reproduction in whole or in part is prohibited without the prior written consent of the copyright owner.
- Applications shown on the herein document are examples of standard use and operation. Customers are responsible in comprehending the suitable use in particular applications. Globaltech Semiconductor makes no representation or warranty that such applications will be suitable for the specified use without further testing or modification.
- The information furnished is believed to be accurate and reliable. However, Globaltech Semiconductor assumes no responsibility for the consequences of use of such information nor for any infringement of patents or other rights of third parties, which may result from its use. No license is granted by implication or otherwise under any patent or patent rights of Globaltech Semiconductor. Specifications mentioned in this publication are subject to change without notice. This publication supersedes and replaces all information without express written approval of Globaltech Semiconductor.

## CONTACT US

GS Headquarter	
	4F.,No.43-1,Lane11,Sec.6,Minquan E.Rd Neihu District Taipei City 114, Taiwan (R.O.C)
	886-2-2657-9980
	886-2-2657-3630
	sales_twn@gs-power.com

RD Division	
	824 Bolton Drive Milpitas. CA. 95035
	1-408-457-0587