

# GS2823

## 300mA High PSRR Low Dropout Voltage Linear Regulators

### Product Description

The GS2823 is a low dropout and low noise linear regulator with high ripple rejection ratio and fast turn-on time. GS2823 is fixed output voltage type. It has fixed output voltage ranging from 1.2V to 4V.

The GS2823 includes a voltage reference unit, an error amplifier, resistor net for voltage setting, a current limit circuit and a chip enable circuit. These ICs perform with low dropout voltage and a chip enable function DFN1x1-4L SOT-23, SOT-23-5L and package only.

The GS2823 works well with low ESR ceramic capacitors, suitable for portable RF and wireless battery-powered applications with stringent space requirements and demanding performance. It also offers ultra low noise output and has low quiescent current.

### Features

- Input Voltage Range: 1.6V to 5.5V
- Low Dropout Voltage: 0.2V at 300mA (Typ) (Vout=3V)
- Output Current: 300mA
- High Ripple Rejection: 80dB (Typ) (f=1kHz)
- Output Voltage: Vout $\geq$ 2V (Accuracy  $\pm$ 1.0%)
- Vout<2V (Accuracy  $\pm$ 20mV)
- Low Supply Current: 150 $\mu$ A (Typ)
- Standby Current: 0.1 $\mu$ A (Typ)
- EN Function: Active High
- Operating Ambient Temperature: -40~+85 $^{\circ}$ C
- Current Limit and Short Circuit Protection
- Fixed Output Voltage: 1.2V to 4.0V
- Low ESR Capacitors: Cin=1 $\mu$ F, CL=1 $\mu$ F
- Miniature Packages: SOT-23, SOT-23-5L, and DFN1x1-4L
- RoHS Compliant, 100%Pb & Halogen Free

### Applications

- Mobile Devices
- Portable Communication Equipment
- Modules
- Hand-Held Instruments
- Wireless Communications

### Block Diagram

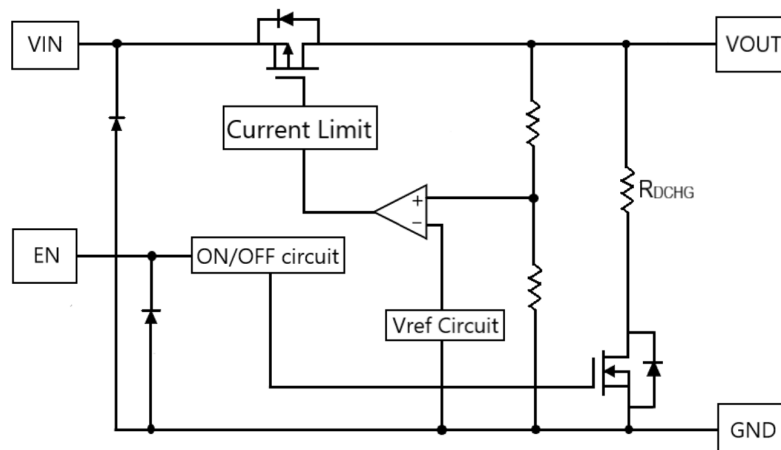

## Packages & Pin Assignments

SOT-23	SOT-23-5L	DFN1X1-4L
Pin Name	Function	
NC	No Connect.	
EN	Enable Input. Pulling this pin below 0.3V turn the regulator off, reducing the quiescent current to a fraction of its operating value. The device will be enabled if this pin is left open. Connect to $V_{IN}$ if not being used.	
GND	Ground Pin.	
$V_{IN}$	Power Supply Input.	
$V_{OUT}$	The pin is the power output of the device.	

## Ordering Information

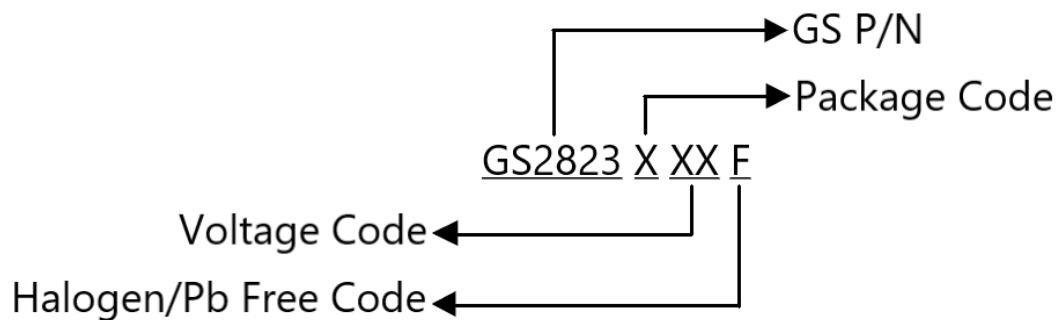

SOT-23	SOT-23-5L	DFN1x1-4L	Output Voltage
GS2823Z12F	GS2823L12F	GS2823F12F	1.2V
GS2823Z15F	GS2823L15F	GS2823F15F	1.5V
GS2823Z18F	GS2823L18F	GS2823F18F	1.8V
GS2823Z25F	GS2823L25F	GS2823F25F	2.5V
GS2823Z28F	GS2823L28F	GS2823F28F	2.8V
GS2823Z30F	GS2823L30F	GS2823F30F	3.0V
GS2823Z33F	GS2823L33F	GS2823F33F	3.3V
GS2823Z40F	GS2823L40F	GS2823F40F	4.0V

## Marking Information

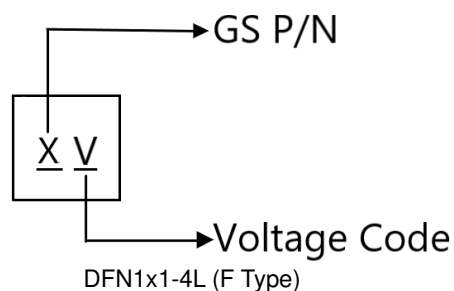
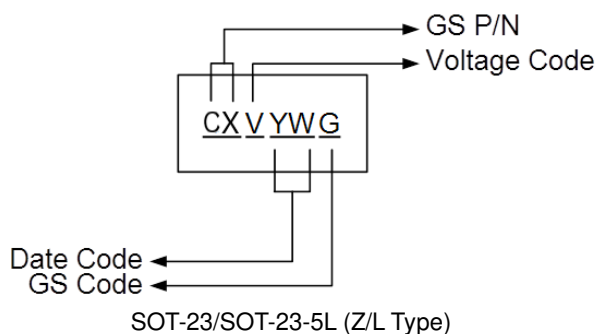

SOT-23	SOT-23-5L	Marking	DFN1x1-4L	Marking	Output Voltage
GS2823Z12F	GS2823L12F	CXD <sub>Y</sub> WG	GS2823F12F	XD	1.2V
GS2823Z15F	GS2823L15F	CXG <sub>Y</sub> WG	GS2823F15F	XG	1.5V
GS2823Z18F	GS2823L18F	CXF <sub>Y</sub> WG	GS2823F18F	XF	1.8V
GS2823Z25F	GS2823L25F	CXH <sub>Y</sub> WG	GS2823F25F	XH	2.5V
GS2823Z28F	GS2823L28F	CXJ <sub>Y</sub> WG	GS2823F28F	XJ	2.8V
GS2823Z30F	GS2823L30F	CXQ <sub>Y</sub> WG	GS2823F30F	XQ	3.0V
GS2823Z33F	GS2823L33F	CXR <sub>Y</sub> WG	GS2823F33F	XR	3.3V
GS2823Z40F	GS2823L40F	CXU <sub>Y</sub> WG	GS2823F40F	XU	4.0V

## Absolute Maximum Ratings

(T<sub>A</sub>=25°C unless otherwise specified)

Symbol	Parameter	Max	Units
V <sub>IN</sub>	Power Supply Voltage	7.0	V
V <sub>EN</sub>	Enable Voltage	7.0	V
V <sub>OUT</sub>	Output Voltage	-0.3 to V <sub>IN</sub>	V
I <sub>OUT</sub>	Output Current	500	mA
P <sub>D</sub>	Power Dissipation	SOT-23-5L	600
		SOT-23	560
		DFN1x1-4L	340
T <sub>STG</sub>	Storage Temperature Range	-55 to 125	°C
T <sub>A</sub>	Operating Ambient Temperature	-40 to 85	°C
T <sub>J</sub>	Operating Junction Temperature	+125	°C
T <sub>LEAD</sub>	Lead Temperature(soldering) 5sec.	260	°C
θ <sub>JA</sub>	Thermal Resistance Junction to Ambient	SOT-23-5L	166
		SOT-23	179
		DFN1x1-4L	294
			°C/W

## Electrical Characteristics

(Unless otherwise specified  $V_{IN}=V_{OUT}+1V$ ,  $T_A=25^{\circ}C$ )

Symbol	Parameter	Conditions	Min	Typ	Max	Unit	
$I_{SS}$	Supply Current	$V_{IN}=V_{OUT}+1.0V$ , En pin=ON, No Load	-	150	-	$\mu A$	
$I_{stand-by}$	Standby Current	$V_{IN}=V_{OUT}+1.0V$ , En pin=OFF, No Load	-	0.01	0.4	$\mu A$	
$V_{IN}$	Input Voltage		1.6	-	5.5	V	
$V_{OUT}$	Output Voltage	$V_{IN}=V_{OUT}+1.0V$ $I_{OUT} = 10mA$	$V_{OUT}<2.0V$	$V_{OUT}-0.02$	$V_{OUT}$	$V_{OUT}+0.02$	V
			$V_{OUT}\geq 2V$	$V_{OUT}\times 0.99$	$V_{OUT}$	$V_{OUT}\times 1.01$	
$I_{OUTMAX}$	Max Output Current	$V_{IN}\geq V_{OUT}+1.0V$	$1.2V\leq V_{OUT}\leq 4.0V$	300	-	-	mA
$\Delta V_{LINE}$	Line regulation	$V_{OUT}+0.5V\leq V_{IN}\leq 5.5V$ $I_{OUT} = 50mA$	$1.2V\leq V_{OUT}\leq 4.0V$	-	0.01	0.1	%/V
$\Delta V_{LOAD}$	Load Regulation	$V_{IN}=V_{OUT}+1V$ $0.1mA\leq I_{OUT}\leq 300mA$	$1.2V\leq V_{OUT}\leq 4.0V$	-	25	45	mV
$V_{DROD}$	Dropout Voltage	$I_{OUT} = 300mA$	$1.2V\leq V_{OUT}<1.3V$	-	0.48	0.63	V
			$1.3V\leq V_{OUT}<1.4V$	-	0.44	0.58	
			$1.4V\leq V_{OUT}<1.5V$	-	0.42	0.52	
			$1.5V\leq V_{OUT}<1.6V$	-	0.42	0.46	
			$1.6V\leq V_{OUT}<1.8V$	-	0.40	0.44	
			$1.8V\leq V_{OUT}<2.0V$	-	0.30	0.41	
			$2.0V\leq V_{OUT}<2.5V$	-	0.27	0.38	
			$2.5V\leq V_{OUT}<3.0V$	-	0.24	0.35	
$3.0V\leq V_{OUT}\leq 4.0V$	-	0.20	0.31				
$\Delta V_{OUT}/\Delta T$	Output Voltage Temperature Coefficient	$V_{IN}=V_{OUT}+1V$ , $I_{OUT}=10mA$ , $-40^{\circ}C\leq T_A\leq 85^{\circ}C$	-	$\pm 100$	-	ppm/ $^{\circ}C$	
PSRR	Power Supply Rejection Ratio	$V_{IN}=V_{OUT}+1V$ $I_{OUT}=30mA$ , $f=1KHZ$	-	80	-	dB	
$V_{EN(HI)}$	EN Input High Voltage	$V_{IN}=V_{OUT}+1V$	1.0	-	-	V	
$V_{EN(LO)}$	EN Input Low Voltage	$V_{IN}=V_{OUT}+1V$	-	-	0.3	V	
$I_{EN(HI)}$	EN Input High Current	$V_{IN}=V_{EN}=5.5V$	3.0	5.5	9.0	$\mu A$	
$I_{EN(LO)}$	EN Input Low Current	$V_{EN}=0V$	-0.1	-	0.1	$\mu A$	
$I_{short}$	Short-Circuit Current	$V_{IN}=V_{OUT}+1.0V$ , En Pin=ON, $V_{OUT}= 0V$	-	50	-	mA	
$I_{LIM}$	Current Limit	$V_{IN}=V_{EN}$	310	400	-	mA	
$I_{RUSH}$	Inrush Current	$V_{IN}=5.5V$ , $V_{EN}=0\sim 5.5V$	-	150	-	mA	
$R_{DCHG}$	On Resistance for Discharge	$V_{IN}=5.5V$ , $V_{OUT}= 2V$ , $V_{EN}=0V$	-	280	-	$\Omega$	

## Typical Applications

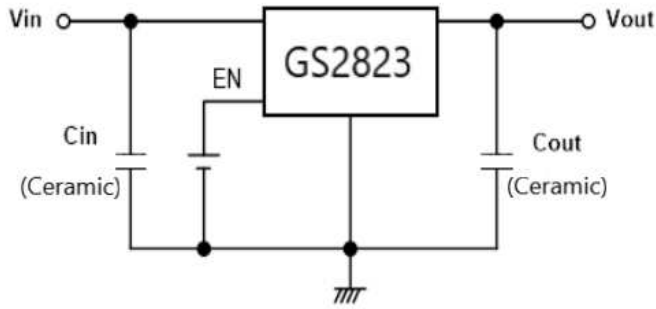

$C_{IN}$  :  $1\mu F$  or more.  $C_{OUT}$  :  $1\mu F$  or more

## Test Circuit

### Operating Function Test

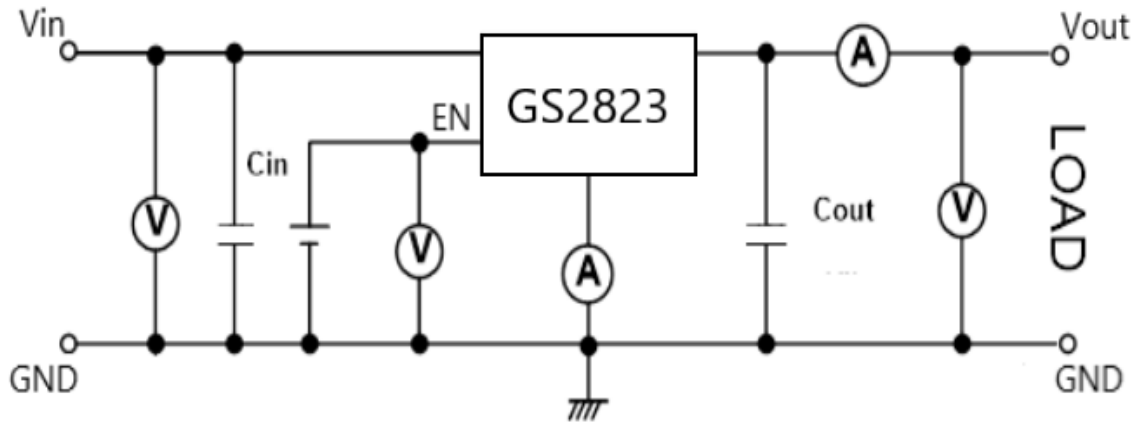

$C_{IN}$  :  $1\mu F$  or more.  $C_{OUT}$  :  $1\mu F$  or more

### Enable Function Test

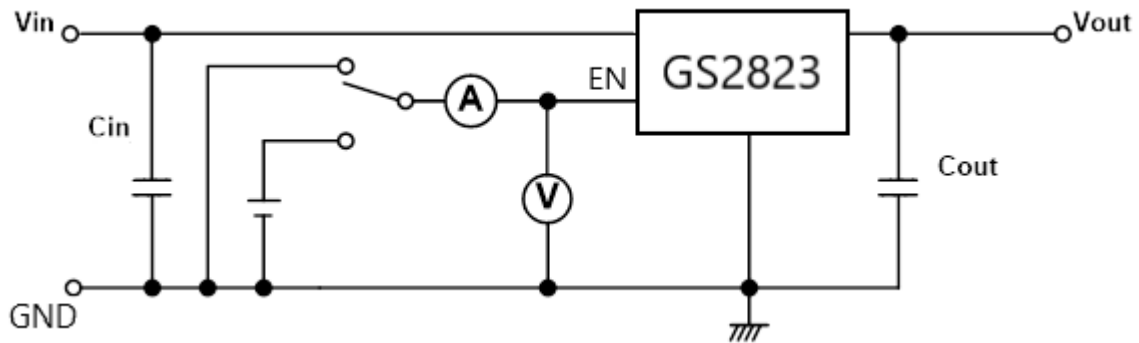

$C_{IN}$  :  $1\mu F$  or more.  $C_{OUT}$  :  $1\mu F$  or more

## Typical Performance Characteristics

### Line Transient response characteristics ( $T_A=25^\circ\text{C}$ )

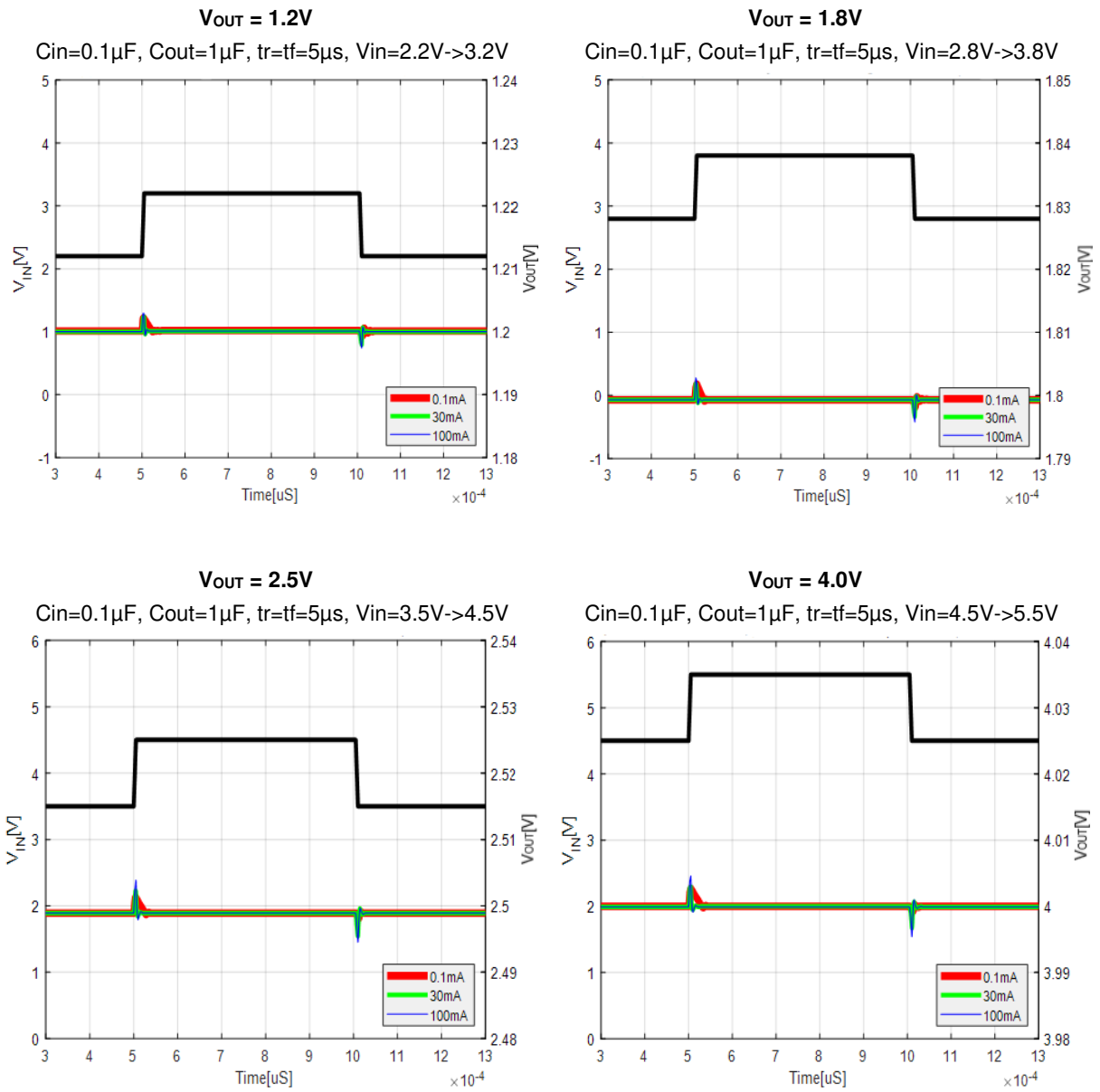

## Load Transient response characteristics (T<sub>A</sub>=25°C)

V<sub>out</sub> = 1.2V

I<sub>out</sub>=1mA~150mA, Tr=Tf=0.5μS, Cin=Cout=1μF

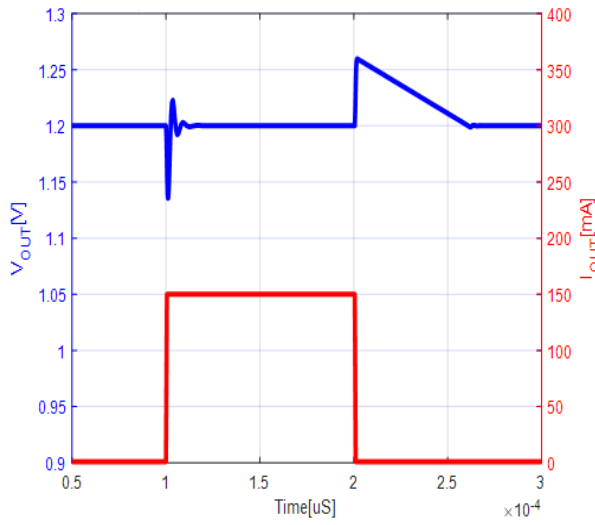

I<sub>out</sub>=50mA~100mA, Tr=Tf=0.5μS, Cin=Cout=1μF

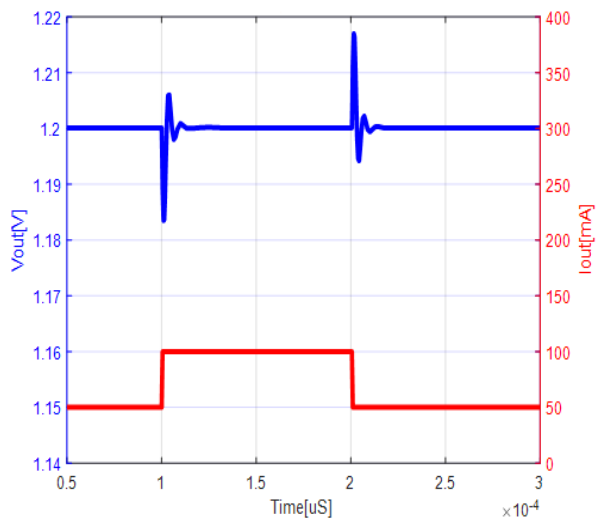

V<sub>out</sub> = 1.8V

I<sub>out</sub>=1mA~150mA, Tr=Tf=0.5μS, Cin=Cout=1μF

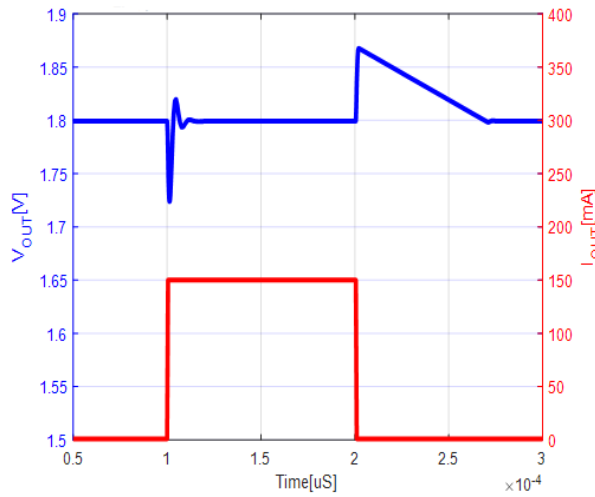

I<sub>out</sub>=50mA~100mA, Tr=Tf=0.5μS, Cin=Cout=1μF

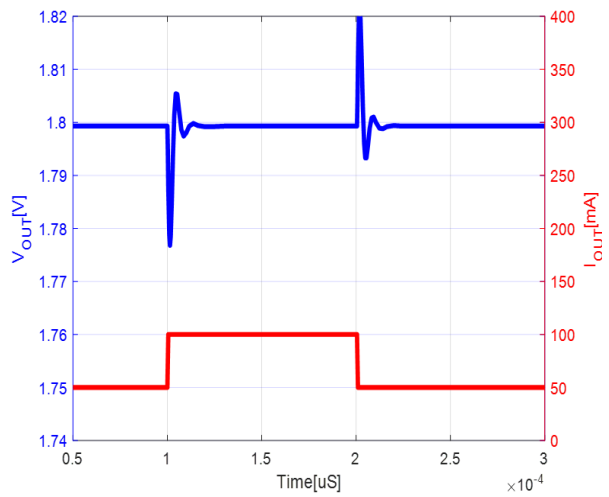

V<sub>out</sub> = 2.5V

I<sub>out</sub>=1mA~150mA, Tr=Tf=0.5μS, Cin=Cout=1μF

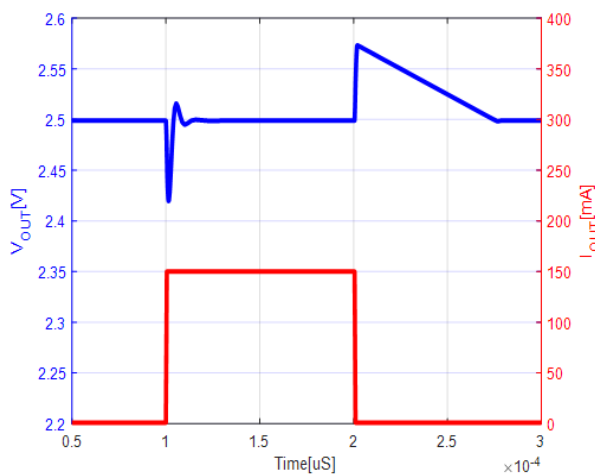

I<sub>out</sub>=50mA~100mA, Tr=Tf=0.5μS, Cin=Cout=1μF

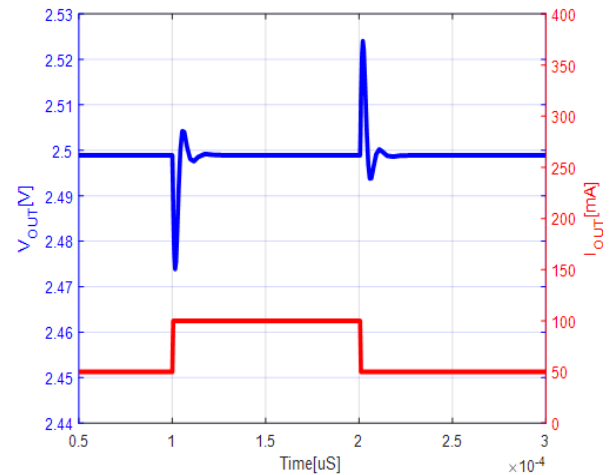

## Load Transient response characteristics (T<sub>A</sub>=25°C)

V<sub>OUT</sub> = 4.0V

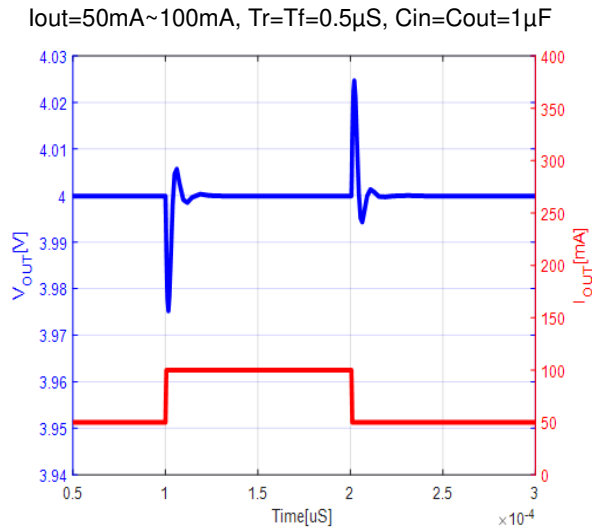
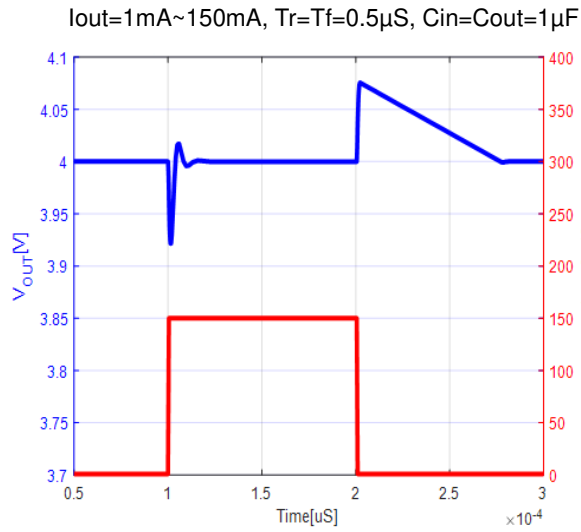

V<sub>OUT</sub> = 1.2V

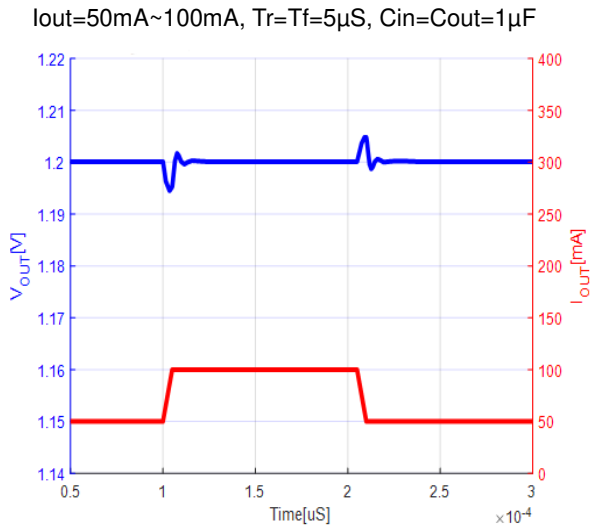
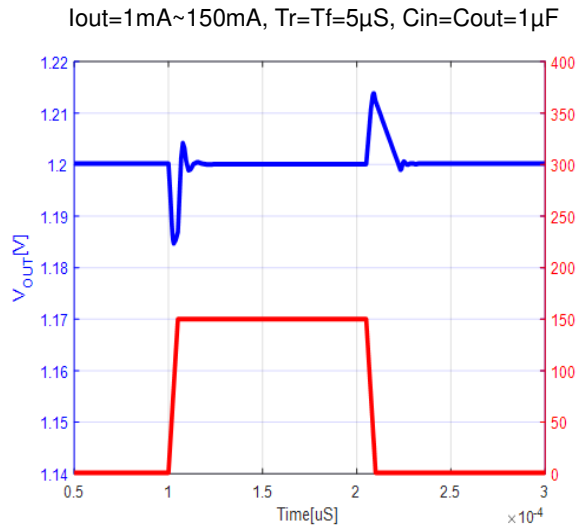

V<sub>OUT</sub> = 1.8V

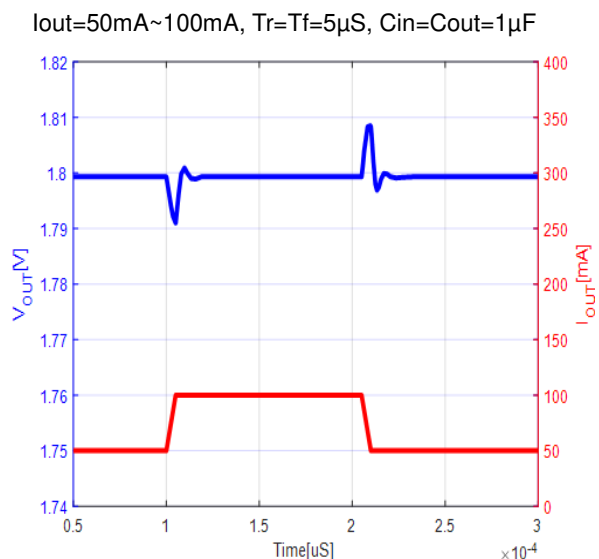
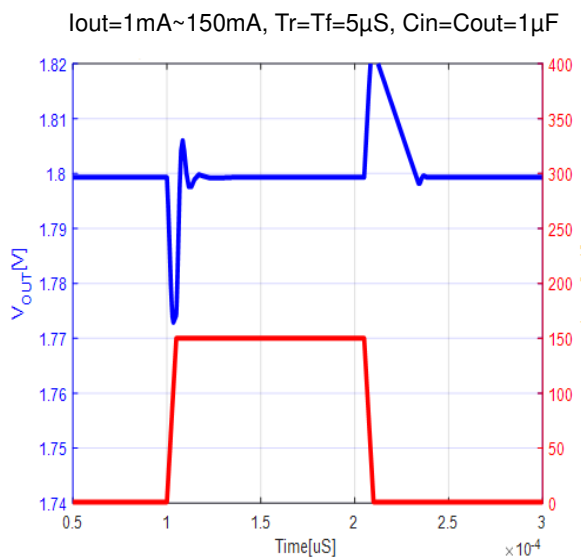

## Load Transient response characteristics (TA=25°C)

V<sub>OUT</sub> = 2.5V

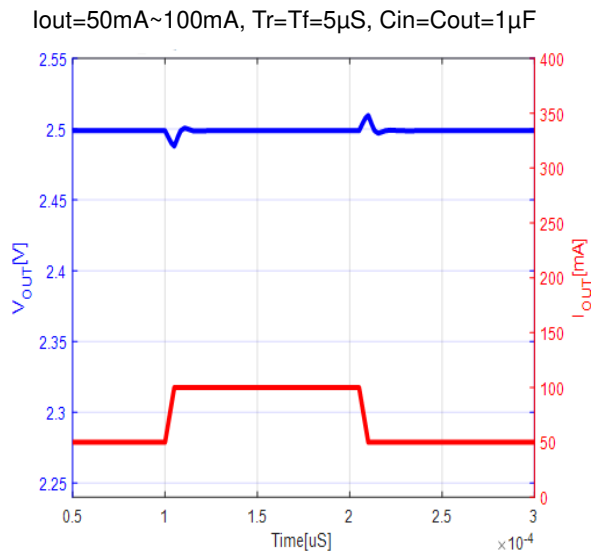
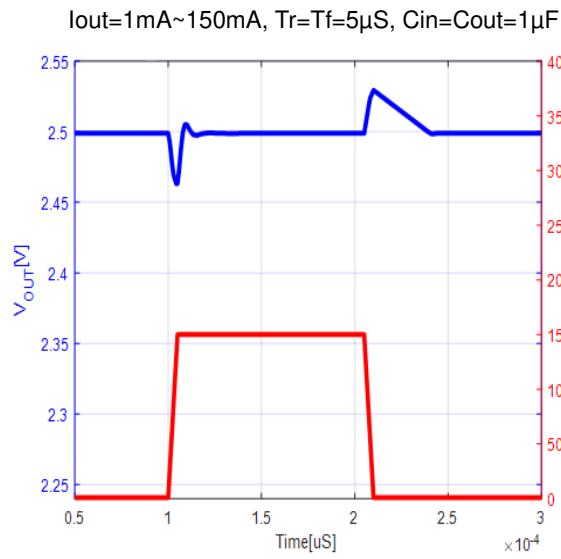

V<sub>OUT</sub> = 4.0V

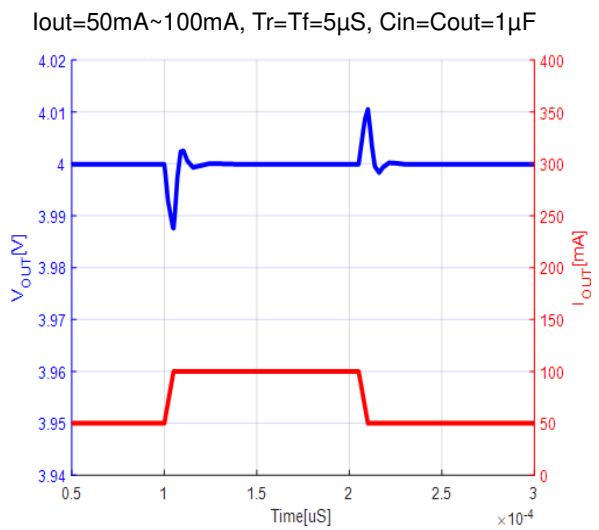
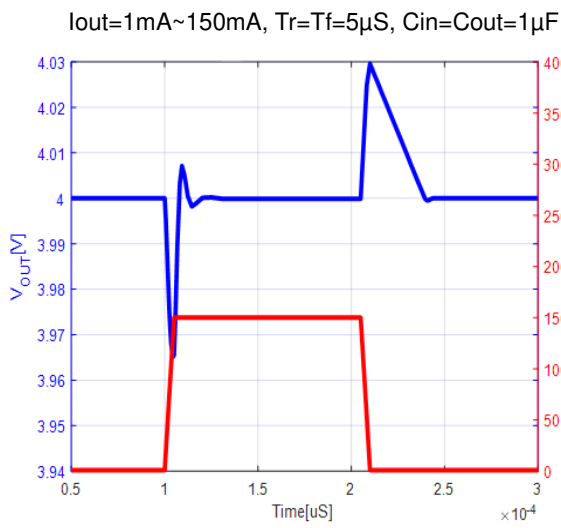

## Ripple rejection ( $T_A=25^\circ\text{C}$ )

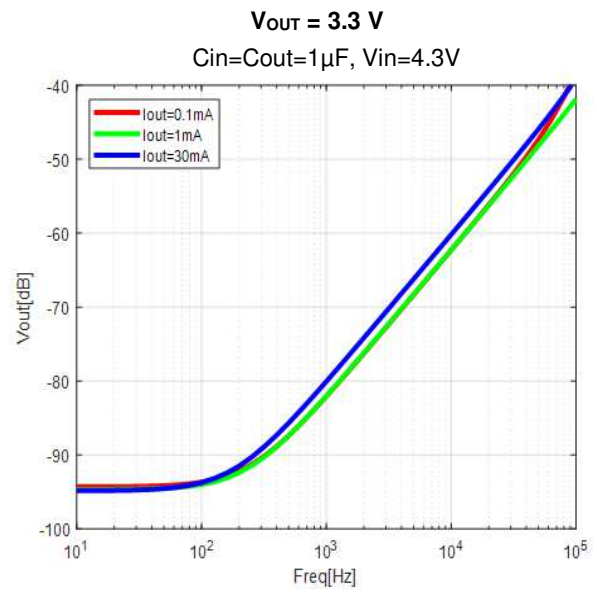
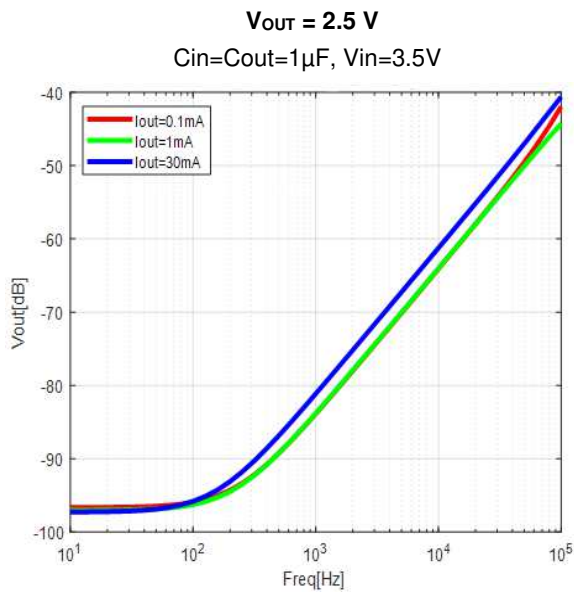
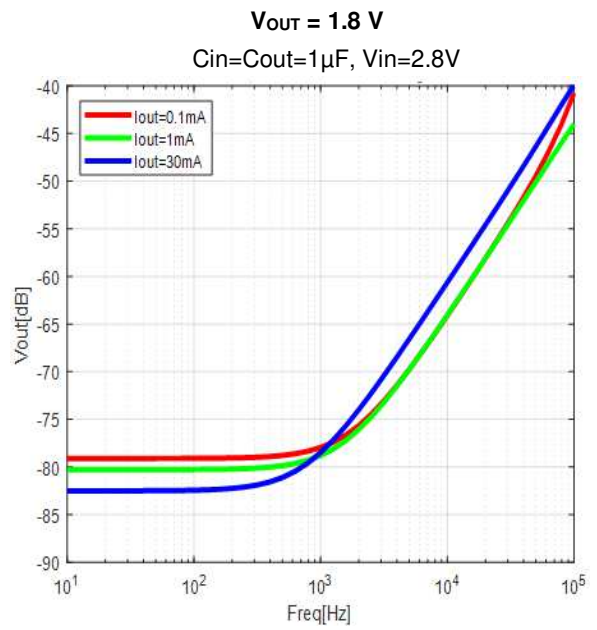
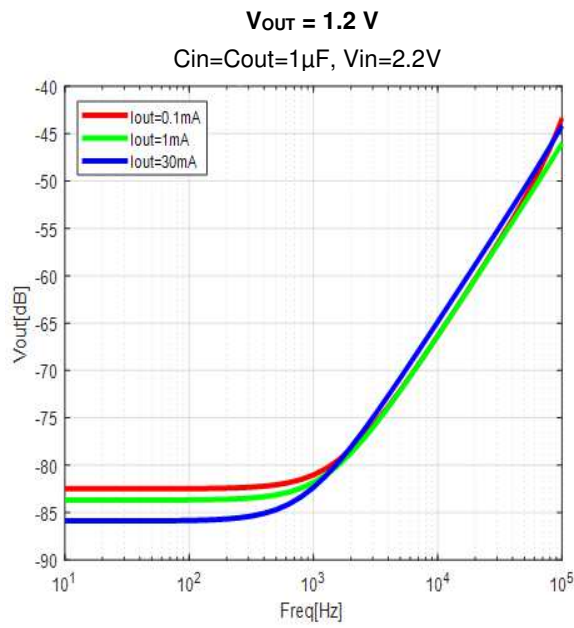

## EN Pin rising response characteristics (T<sub>A</sub>=25°C)

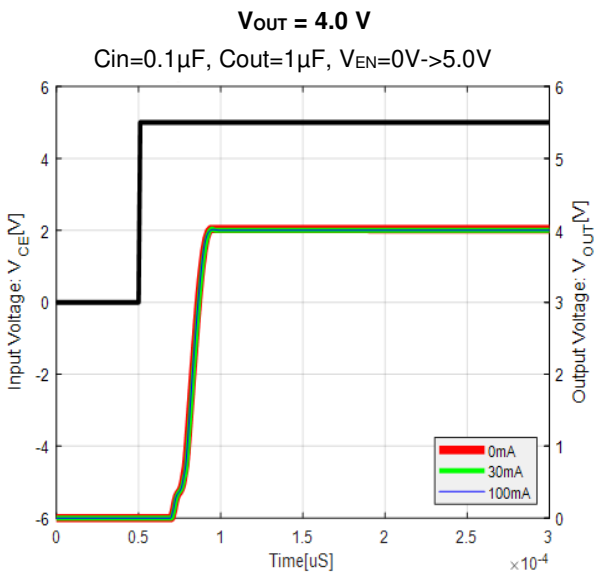
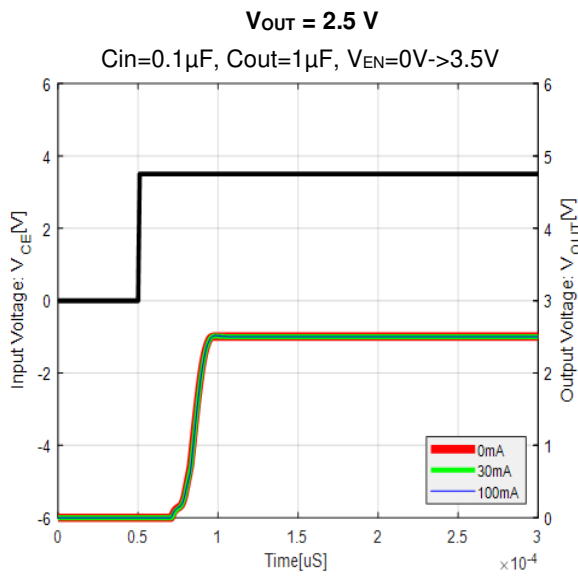
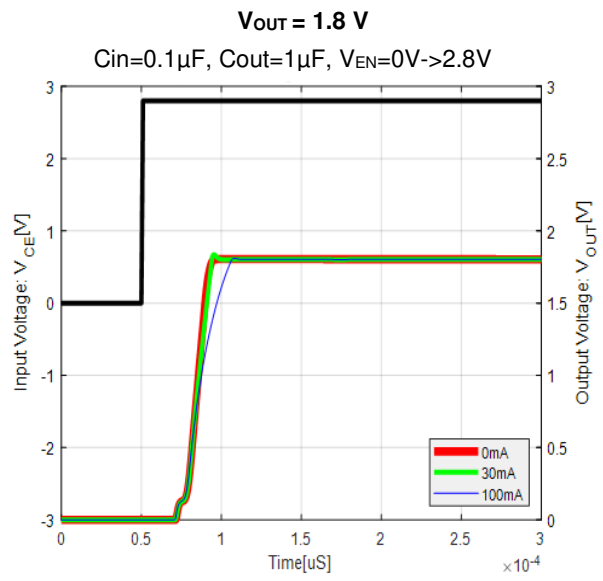
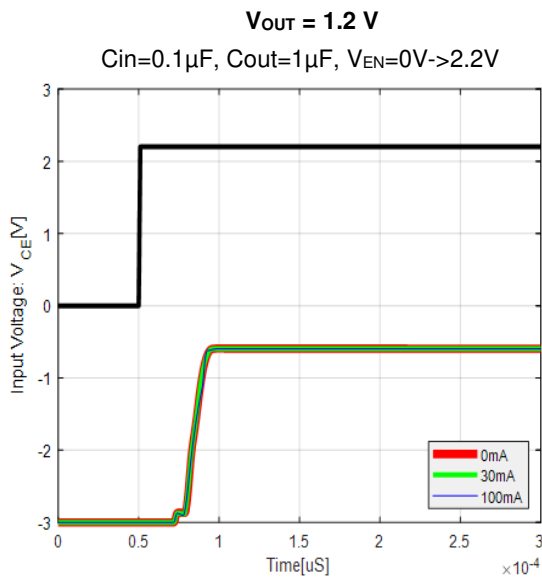

## Inrush Current Response Time( $T_A=25^\circ\text{C}$ )

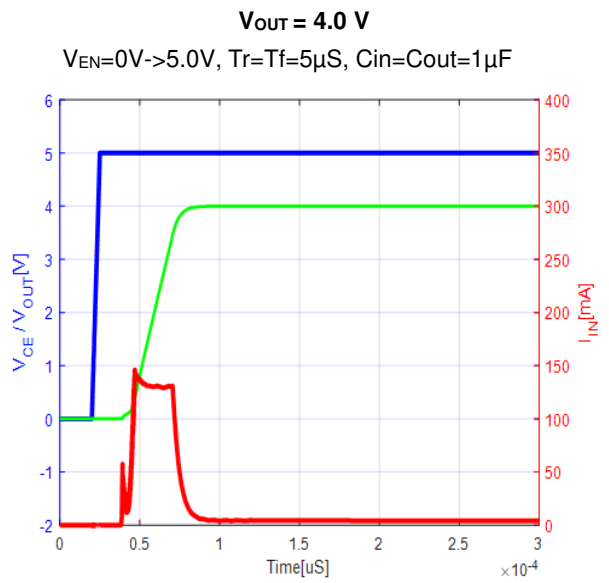
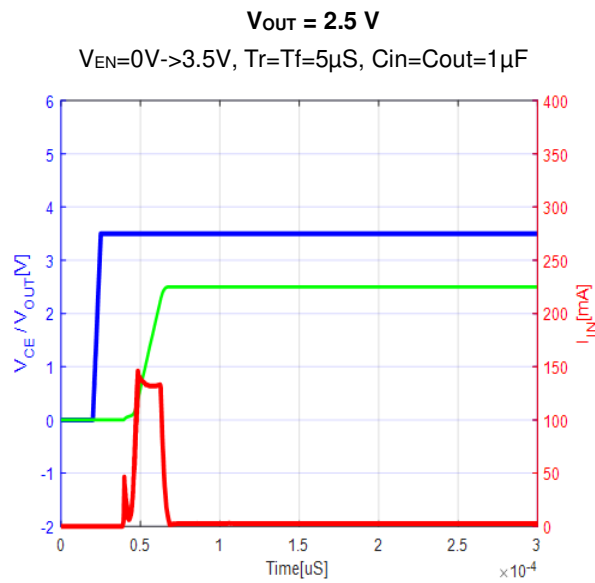
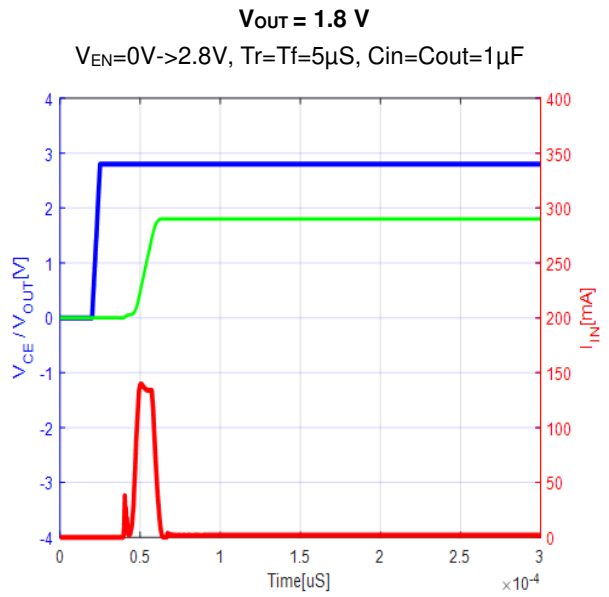
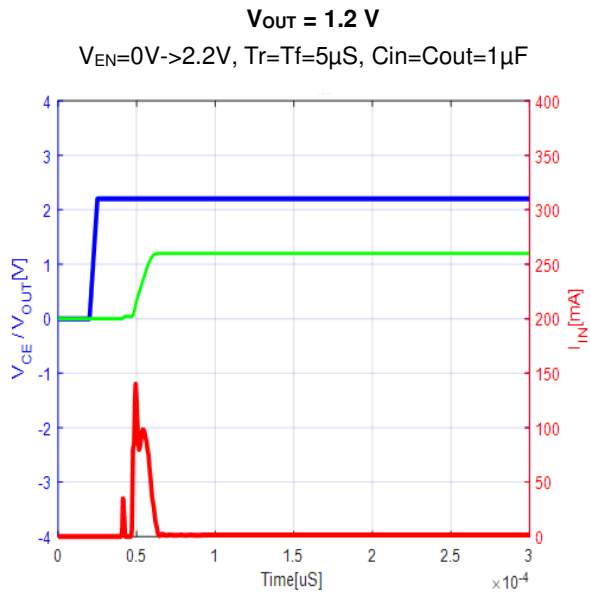

## Package Dimension

### SOT-23

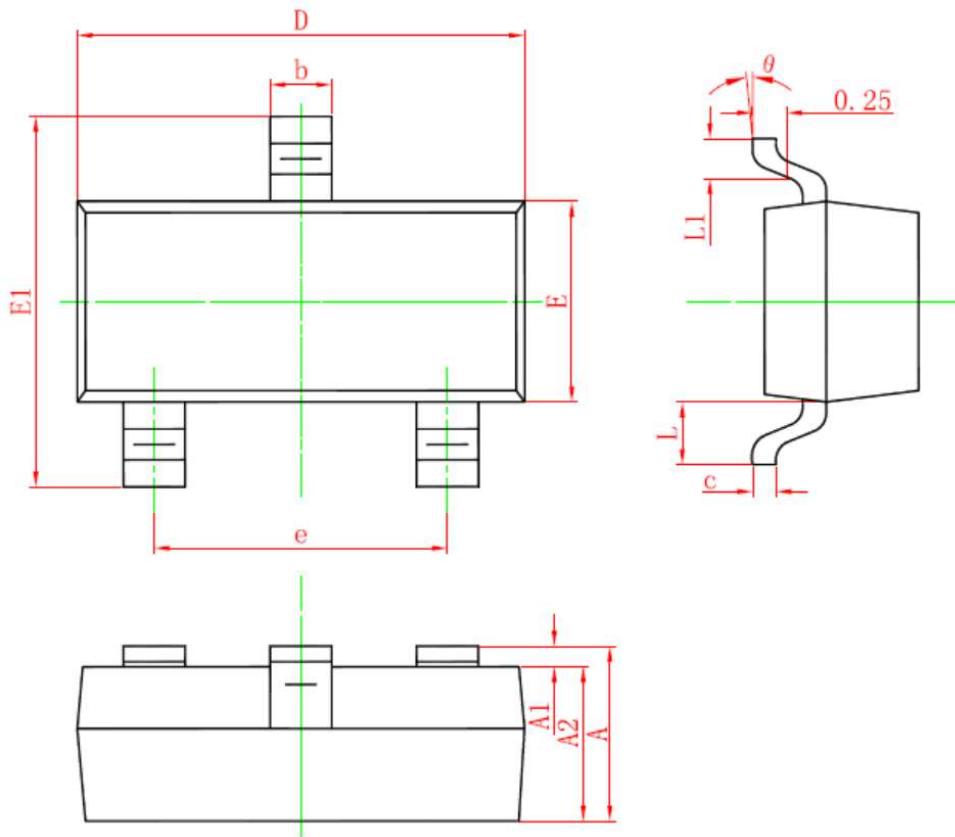

### Dimensions

SYMBOL	Millimeters		Inches	
	MIN	MAX	MIN	MAX
A	0.75	1.15	0.030	0.045
A1	0.00	0.10	0.000	0.004
A2	0.90	1.10	0.035	0.043
b	0.30	0.50	0.012	0.020
c	0.13	0.20	0.005	0.008
D	2.80	3.00	0.110	0.118
E	1.20	1.40	0.047	0.055
E1	2.25	2.55	0.089	0.100
e	1.90 (TYP)		0.075 (TYP)	
L	0.55 (TYP)		0.022 (TYP)	
L1	0.30	0.50	0.012	0.020
θ	0°	8°	0°	8°

# SOT-23-5L

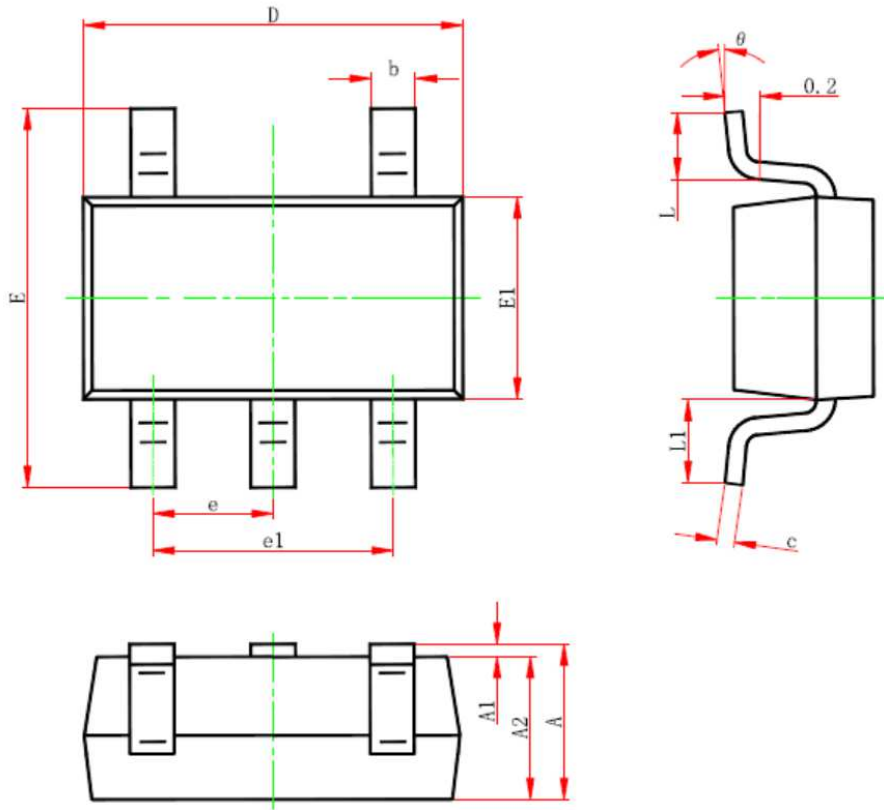

## Dimensions

SYMBOL	Millimeters		Inches	
	MIN	MAX	MIN	MAX
<b>A</b>	1.05	1.25	0.041	0.049
<b>A1</b>	0.00	0.10	0.000	0.004
<b>A2</b>	1.05	1.15	0.041	0.045
<b>b</b>	0.30	0.50	0.012	0.020
<b>c</b>	0.10	0.20	0.004	0.008
<b>D</b>	2.82	3.02	0.111	0.119
<b>E</b>	2.65	2.95	0.104	0.116
<b>E1</b>	1.50	1.70	0.059	0.067
<b>e</b>	0.95 (TYP)		0.037 (TYP)	
<b>e1</b>	1.90 (TYP)		0.075 (TYP)	
<b>L</b>	0.30	0.60	0.012	0.024
<b>L1</b>	0.60 (TYP)		0.024 (TYP)	
<b>θ</b>	0°	8°	0°	8°

# DFN1x1-4L

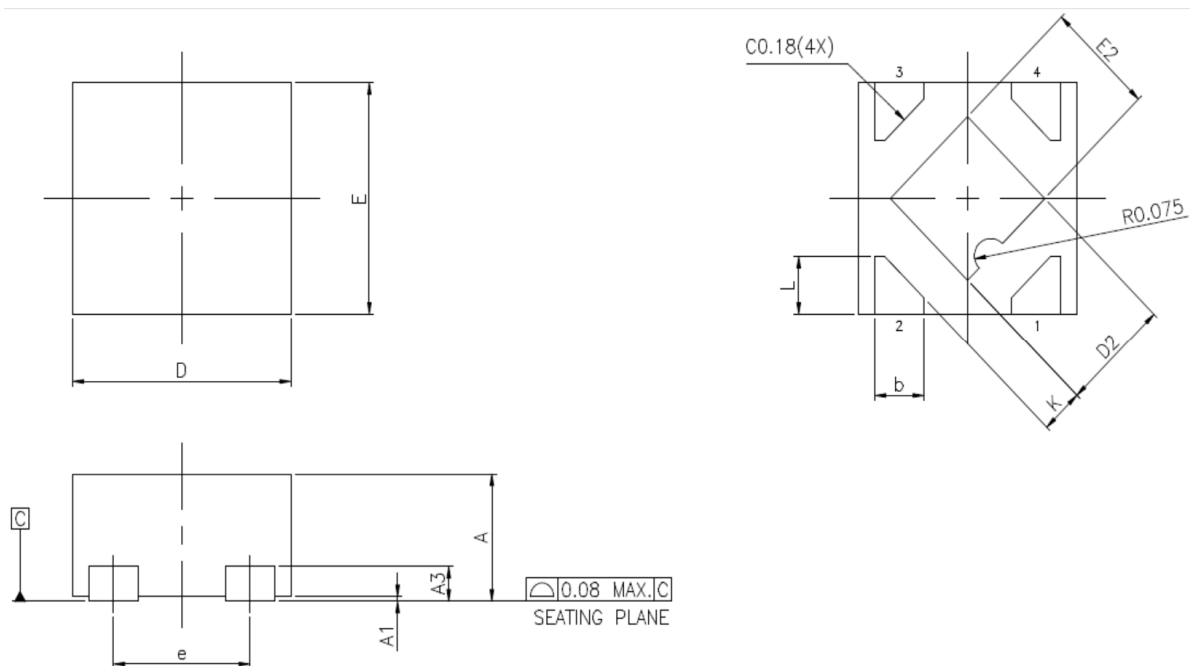

## Dimensions

SYMBOL	Millimeters		Inches	
	MIN	MAX	MIN	MAX
A	0.500	0.600	0.019	0.023
A1	0.000	0.050	0.000	0.002
A3	0.150MAX.		0.005MAX.	
D	1.000TYP.		0.039TYP.	
E	1.000TYP.		0.039TYP.	
E2	0.500TYP.		0.020TYP.	
D2	0.500TYP.		0.020TYP.	
b	0.175	0.275	0.007	0.011
k	0.200MIN.		0.007MIN.	
e	0.625TYP.		0.025TYP.	
L	0.200	0.300	0.007	0.011

## Recommended Footprint (SOT-23)

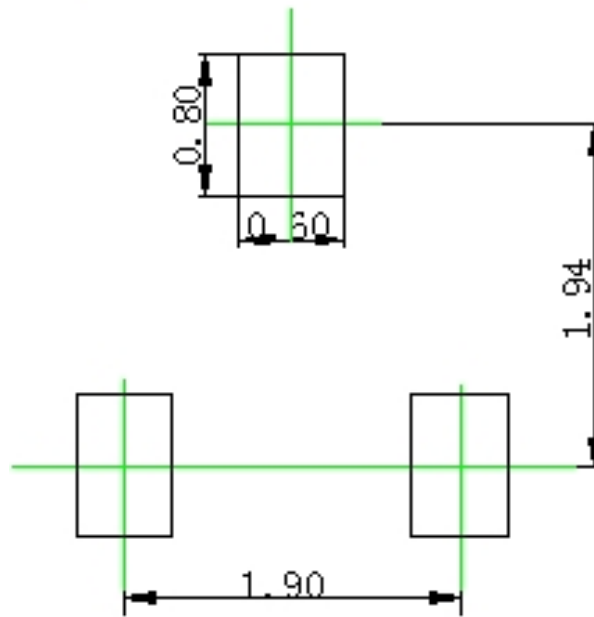

Dimensions : Millimeters

## Recommended Footprint (SOT-23-5L)

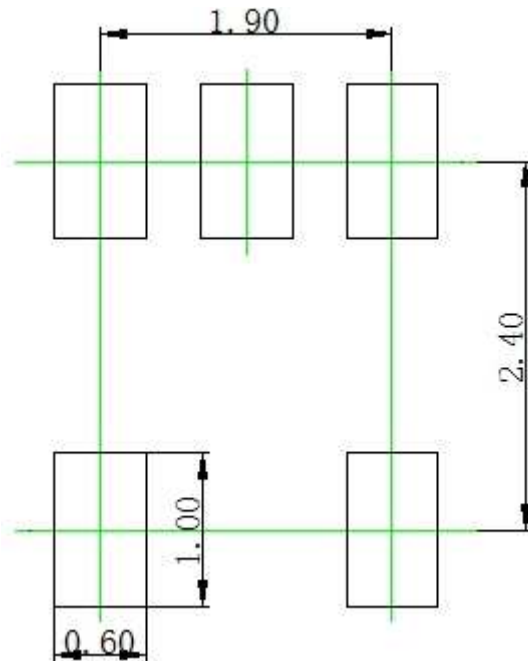

Dimensions : Millimeters

## Recommended Footprint (DFN1X1-4L)

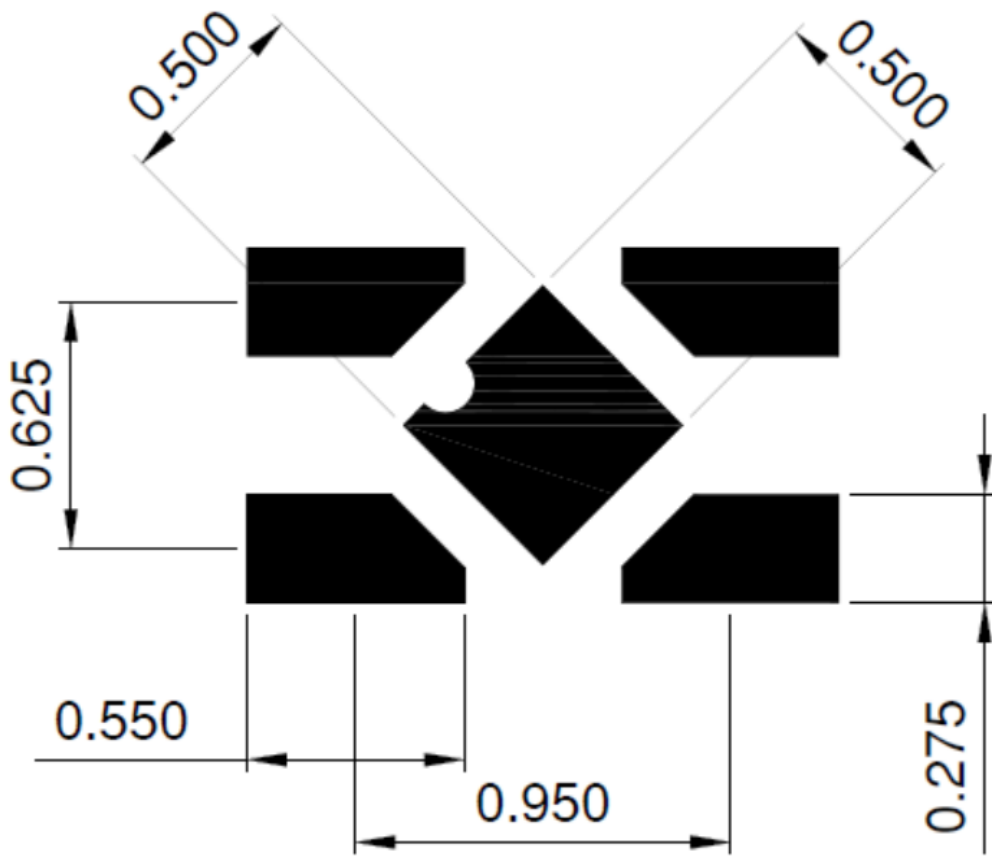







Dimensions : Millimeters

## NOTICE

Information furnished is believed to be accurate and reliable. However Globaltech Semiconductor assumes no responsibility for the consequences of use of such information nor for any infringement of patents or other rights of third parties, which may result from its use. No license is granted by implication or otherwise under any patent or patent rights of Globaltech Semiconductor. Specifications mentioned in this publication are subject to change without notice. This publication supersedes and replaces all information without express written approval of Globaltech Semiconductor.

## CONTACT US

GS Headquarter	
	4F.,No.43-1,Lane11,Sec.6,Minquan E.Rd Neihu District Taipei City 114, Taiwan (R.O.C)
	886-2-2657-9980
	886-2-2657-3630
	sales_twn@gs-power.com

RD Division	
	824 Bolton Drive Milpitas. CA. 95035
	1-408-457-0587