

GS5801

3W, 0.85V Startup Voltage, Synchronous Step-Up Converter

Product Description

The GS5801 is a high efficiency synchronous step-up converter that can provide up to 3W of power to a boosted output from a low voltage source. Unlike most step-up converter, not only it starts up at a very low input voltage as low as 0.85V, it also incorporates circuits that disconnect the input from output, during shutdown, short-circuit, output current overloading, or other events when output is higher than the input. This eliminates the need for an external MOSFET and its control circuitry to disconnect the input from output, and provides robust output overload protection.

The GS5801 starts up from a voltage as low as 0.85V making it ideal for applications with single-cell or two-cell alkaline, NiCd, and NiMh batteries. A switching frequency of 2MHz minimizes solution footprint by allowing the use of tiny and low profile inductors and ceramic capacitors. An internal synchronous MOSFET provides highest efficiency and with a current mode control that is internally compensated, external parts count is reduced to minimal.

Features

- Output Disconnect
- Short-circuit Protection
- 3W Output Power
- Output to Input Reversed Current Protection
- 0.85V Low Start-up Voltage
- V_{IN} range from 0.6V to 4.5V
- Fixed Output Voltage : 2.1V, 3.3V and 5V
- Up to 96% Efficiency
- 40 μ A No load I_Q and light load PFM Mode
- Internal Synchronous Rectifier
- Current Mode control
- Logic Control Shutdown and Thermal shutdown
- Miniature Packages : SOT-23-5L
- RoHS Compliant, 100%Pb & Halogen Free

Applications

- USB OTG for MIDs, Smart phones
- Mobile back-up Battery Chargers
- Alkaline, NiCd, and NiMh batteries applications
- USB powered devices

Block Diagram

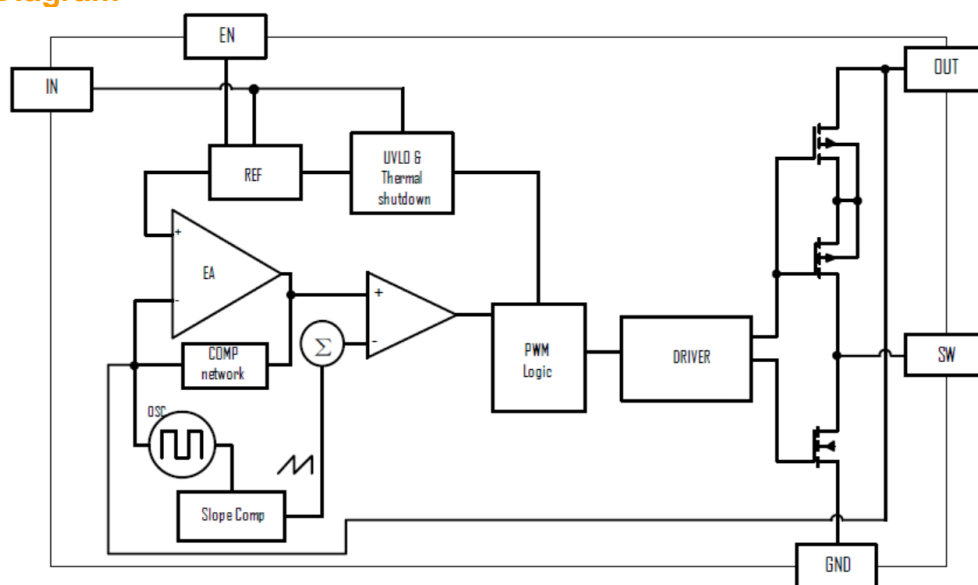

Fixed Voltage Type

Packages & Pin Assignments

SOT-23-5L (Fixed)	
Pin Name	Function
EN	Enable pin for the IC. Drive this pin high to enable the part, low to disable.
OUT	Output pin. Bypass with a 22 μ F or larger ceramic capacitor closely between this pin and GND.
GND	Ground Pin.
SW	Inductor Connection. Connect an inductor Between SW and the regulator output.
IN	Input Supply Voltage. Bypass with a 4.7 μ F ceramic capacitor to GND.

Ordering Information

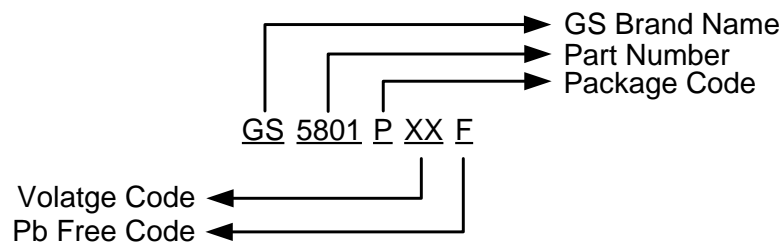

Marking Information

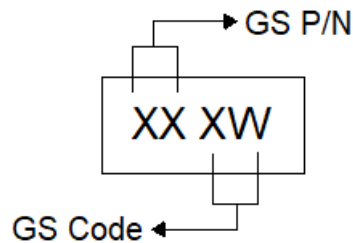

Part Number	Package	Marking
GS5801L21F	SOT-23-5L	DaXW
GS5801L33F	SOT-23-5L	DzXW
GS5801L50F	SOT-23-5L	CPXW

Absolute Maximum Ratings

Symbol	Description	Value	Units
V_{SW}	SW Voltage	-0.3 to 5.5	V
	All Other Pin Voltages	-0.3 to 5	V
I_{PEAK}	SW to Ground Current	Internally limited	
θ_{JA}	Thermal Resistance Junction to Ambient	SOT-23-5L	220 °C/W
θ_{JC}	Thermal Resistance Junction to Case	SOT-23-5L	110 °C/W
T_A	Operating Temperature Range	-40 to +85	°C
T_{STG}	Storage Temperature Range	-55 to +150	°C

Electrical Characteristics

$V_{IN}=1.8V$, $V_{OUT}=3.3V$, $T_A=25^{\circ}C$, unless otherwise noted.

Symbol	Parameter	Test Conditions	Min	Typ	Max	Unit
V_{IN}	Minimum Input Voltage	-	-	0.6	-	V
-	Startup Voltage	$I_{OUT}=0A$	-	0.85	1.1	V
V_{OUT}	Output Voltage (Fix Mode)	$V_{IN}=1.8V$	-	2.1	-	V
			-	3.3	-	V
			-	5.0	-	V
I_Q	Quiescent Current	$V_{FB}=0.7V$	-	40	-	μA
I_{SHUT}	Shutdown Current	$V_{EN}=GND$	-	0.5	5	μA
F_{SW}	Switching Frequency	$V_{IN}<4.3V$	1.2	2	2.4	MHz
$D(MAX)$	Maximum Duty Cycle	$V_{FB}=0V$	90	-	-	%
V_{EH}	EN Input High Voltage	-	0.6	-	-	V
V_{EL}	EN Input Low Voltage	-	-	-	0.3	V
$R_{DS(ON)_H}$	NMOS Switching On Resistance	$I_{SW}=100mA$	-	150	350	$m\Omega$
$R_{DS(ON)_L}$	PMOS Switching On Resistance	$I_{SW}=100mA$	-	150	350	$m\Omega$
I_{SW_LIM}	NMOS Switch Current Limit	-	1.2	1.5	-	A
-	Start-up Current Limit	-	-	0.5	-	A
-	Output to Input Reverse Leakage Current	$V_{EN}=GND$	-	0.1	5	μA
-	SW Leakage Current	$V_{OUT}=5V$, $V_{SW}=0V$ or $5V$, $V_{EN}=GND$	-	-	10	μA
I_{EN}	EN Input Current	-	-	0.1	1	μA
T_{SD}	Thermal Shutdown	Rising, Hysteresis= $10^{\circ}C$	-	165	-	°C

Typical Application Circuit

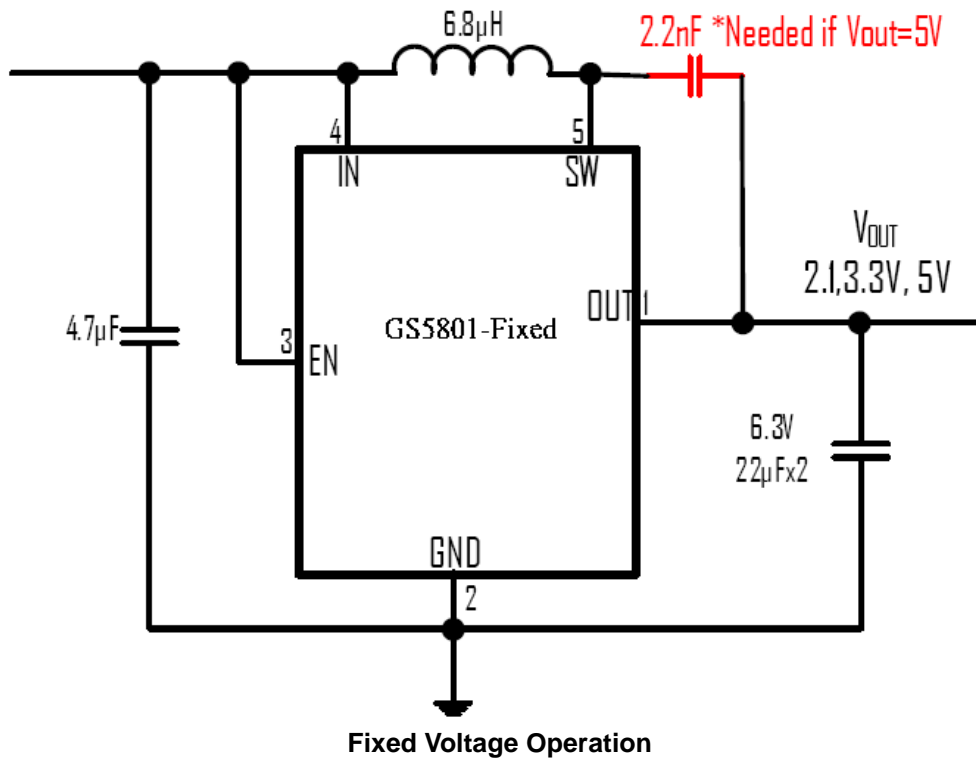

Typical Performance Characteristics

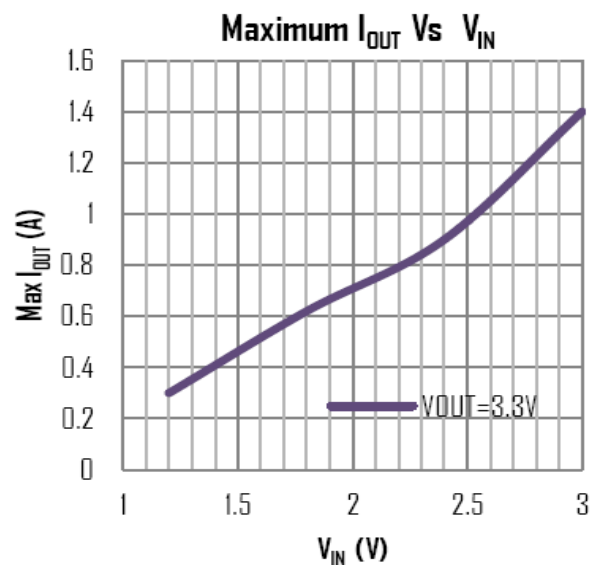
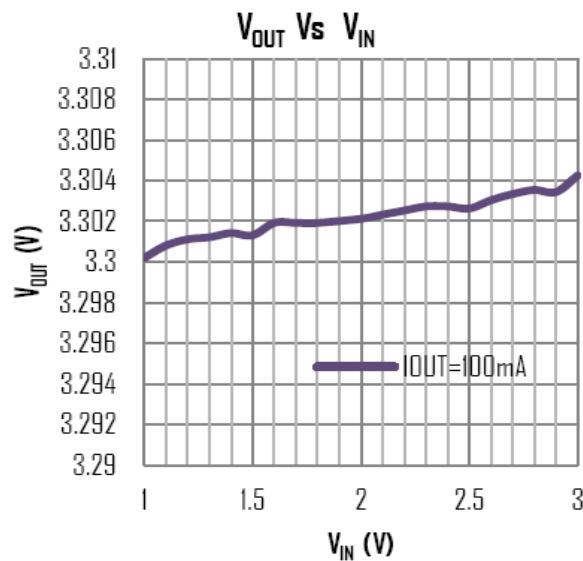
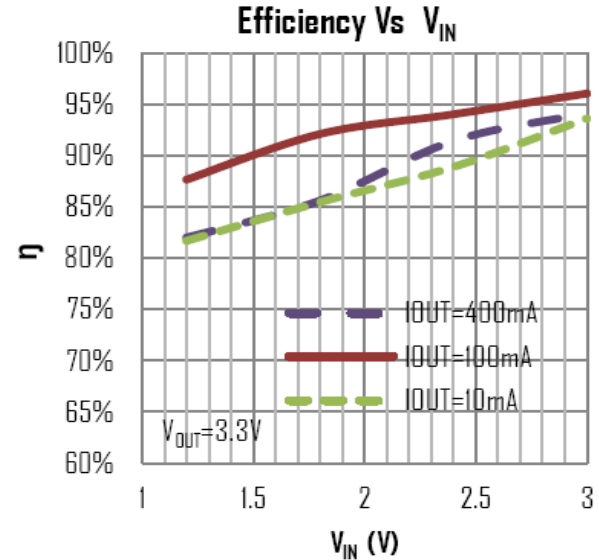
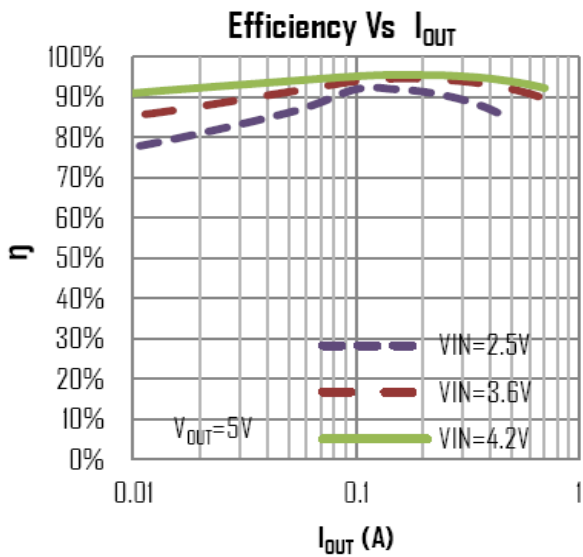
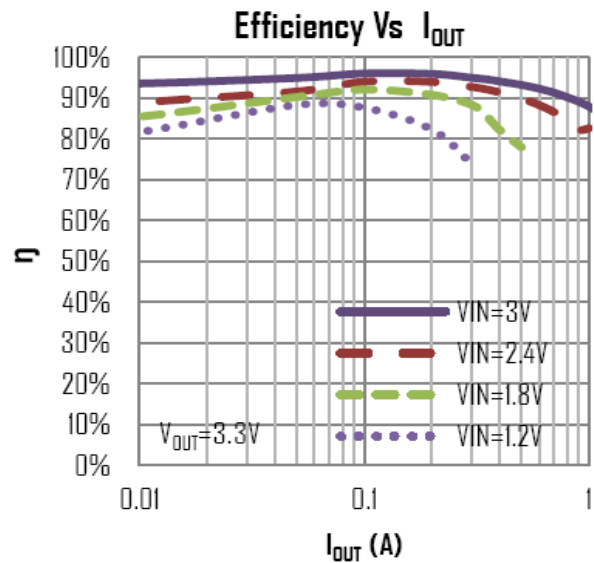
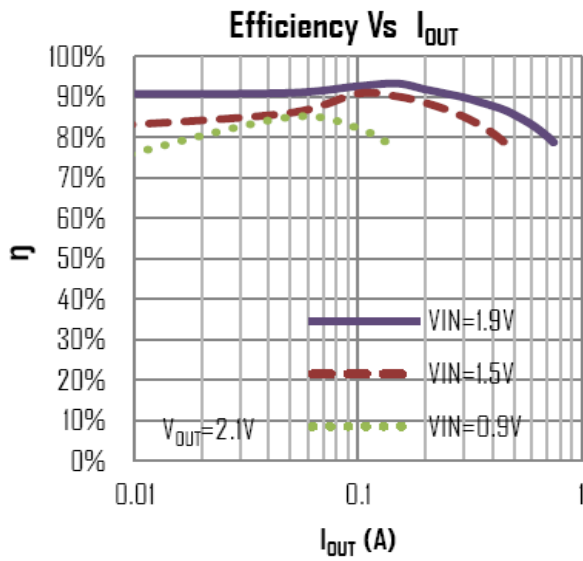

Typical Performance Characteristics

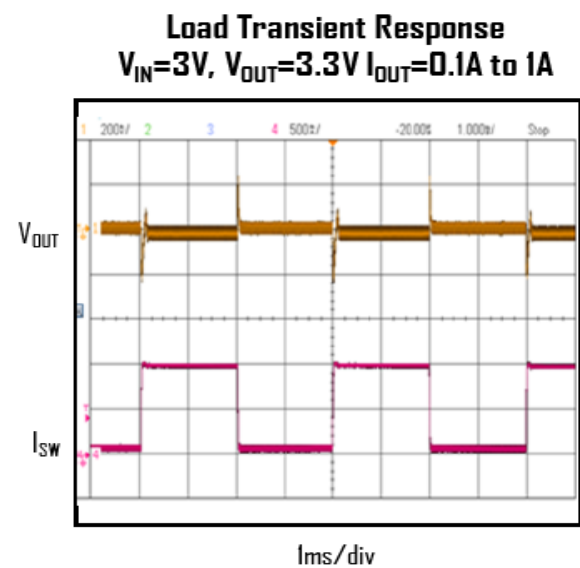
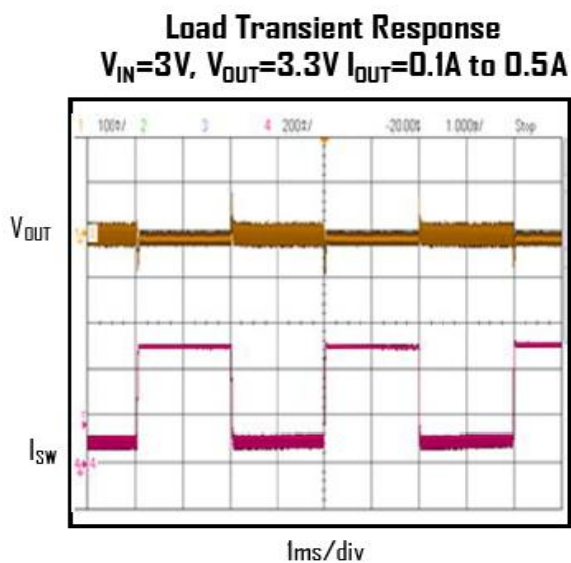
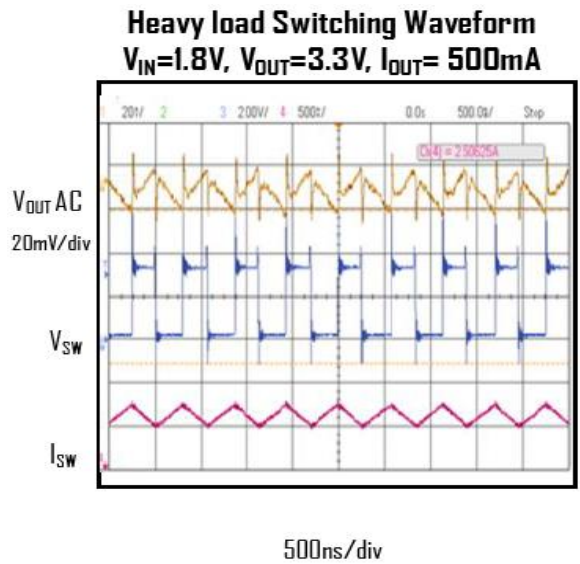
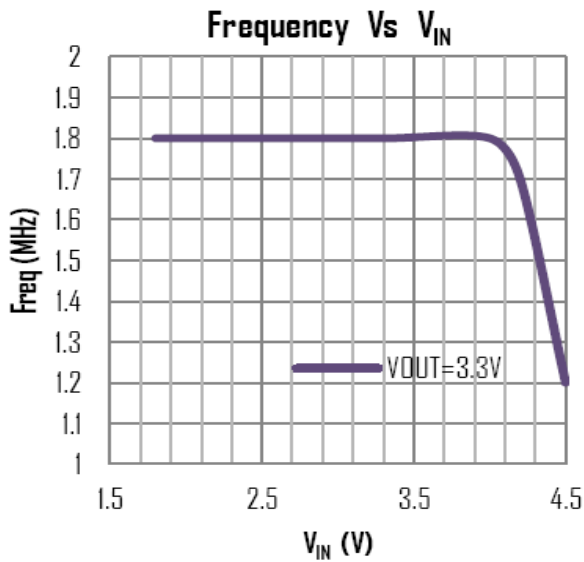
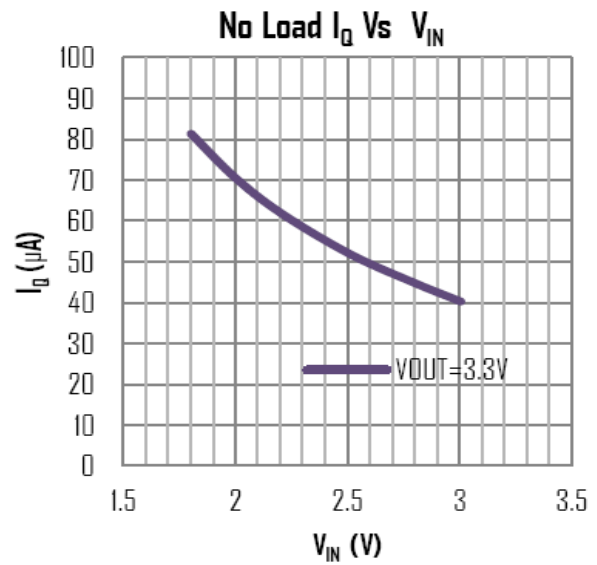
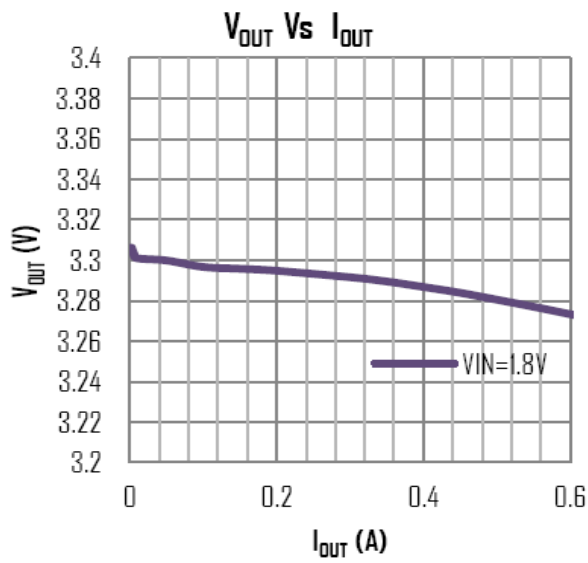

Applications Information

Loop Operation

The GS5801 is a wide input range, high-efficiency, DC-to-DC step-up switching regulator, capable of delivering up to 3W of output power, integrated with a 150mΩ high side MOSFET and 150mΩ synchronous rectifier. It uses a PWM current-mode control scheme. An error amplifier integrates error between the FB signal and the internal reference voltage. The output of the integrator is then compared to the sum of a current-sense signal and the slope compensation ramp. This operation generates a PWM signal that modulates the duty cycle of the power MOSFETs to achieve regulation for output voltage.

Light Load Operation

Traditionally, a fixed constant frequency PWM DC-DC regulator always switches even when the output load is small. When energy is shuffling back and forth through the power MOSFETs, power is lost due to the finite $R_{DS(ON)}$ of the MOSFETs and parasitic capacitances. At light load, this loss is prominent and efficiency is therefore very low. GS5801 employs a proprietary control scheme that improves efficiency in this situation by enabling the device into a power save mode during light load, thereby extending the range of high efficiency operation.

Short-Circuit Protection

Unlike most step-up converters, the GS5801 allows for short circuits on the output. In the event of a short circuit, the device first turns off the NMOS when the sensed current reaches the current limit. After V_{OUT} drops below V_{IN} the device then enters a linear charge period with the current limited same as with the start-up period. In addition, the thermal shutdown circuits disable switching if the die temperature rises above 165°C.

Down Mode ($V_{IN} > V_{OUT}$) Operation

The GS5801 will continue to supply the output voltage even when the input voltage exceeds the output voltage. Since the PMOS no longer acts as a low-impedance switch in this mode, power dissipation increases within the IC to cause a sharp drop in efficiency. Limit the maximum output current to maintain an acceptable junction temperature.

5V Applications

When output voltage is programmed to above 4.5V, in order to maintain an acceptable peak voltage at SW, a small parallel capacitor snubber between SW and OUT is necessary, and an output cap of greater than 44μF is also required as shown in below figure.

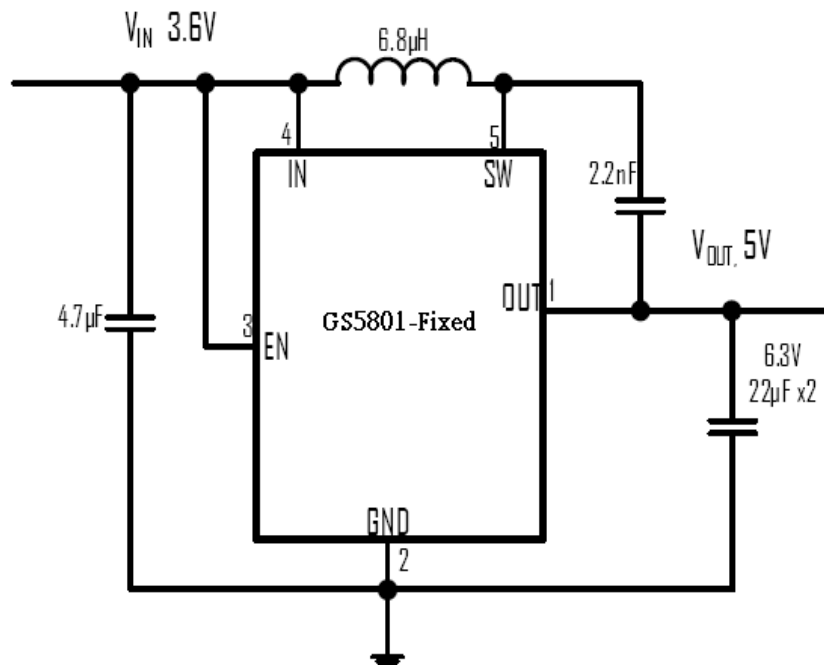

Package Dimension

SOT-23-5L

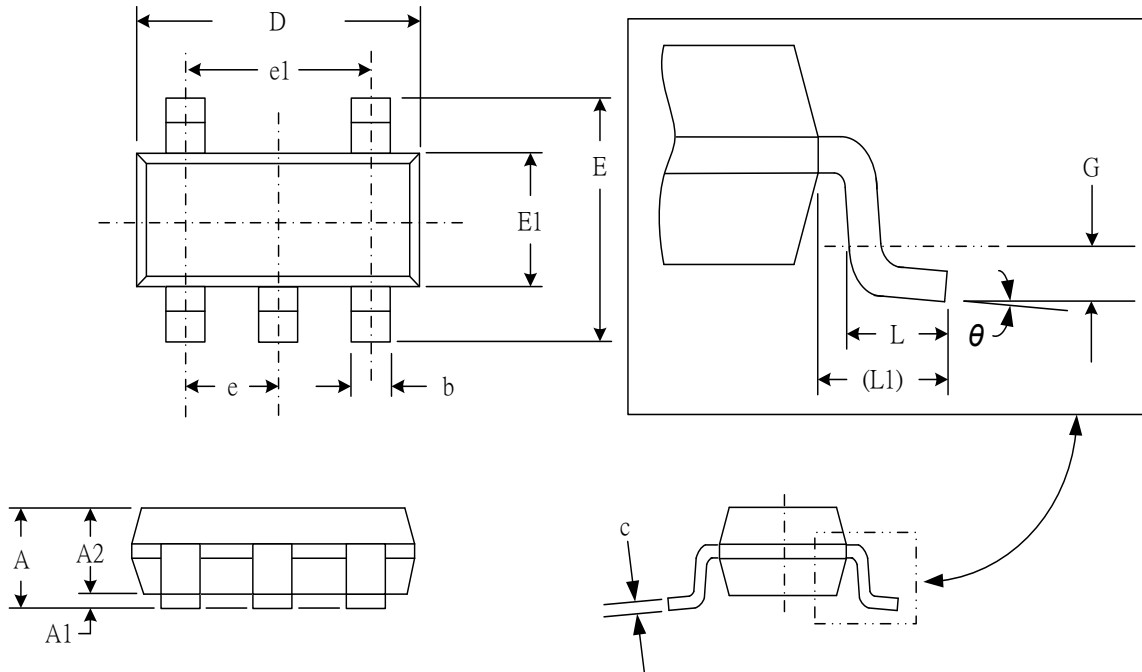







Dimensions				
SYMBOL	Millimeters		Inches	
	MIN	MAX	MIN	MAX
A	0.95	1.45	.037	.057
A1	0.05	0.15	.002	.006
A2	0.90	1.30	.035	.051
b	0.30	0.50	.012	.020
c	0.08	0.20	.003	.008
D	2.80	3.00	.110	.118
E	2.60	3.00	.102	.118
E1	1.50	1.70	.059	.067
e	0.95 (TYP)		.037 (TYP)	
e1	1.90 (TYP)		.075 (TYP)	
L	0.35	0.55	.014	.022
L1	0.60 (TYP)		.024 (TYP)	
G	0.25 (TYP)		.010 (TYP)	
θ	0°	8°	0°	8°

NOTICE

Information furnished is believed to be accurate and reliable. However Globaltech Semiconductor assumes no responsibility for the consequences of use of such information nor for any infringement of patents or other rights of third parties, which may result from its use. No license is granted by implication or otherwise under any patent or patent rights of Globaltech Semiconductor. Specifications mentioned in this publication are subject to change without notice. This publication supersedes and replaces all information without express written approval of Globaltech Semiconductor.

CONTACT US

GS Headquarter	
	4F.,No.43-1,Lane11,Sec.6,Minquan E.Rd Neihu District Taipei City 114, Taiwan (R.O.C)
	886-2-2657-9980
	886-2-2657-3630
	sales_twn@gs-power.com

RD Division	
	824 Bolton Drive Milpitas. CA. 95035
	1-408-457-0587